



BOOK ITALIA 2009

BY ALDO LARCHER





D O V E C



'È VITA



INDICE



BALAUSTRE
PAGINA 6-71



PILASTRI BLOCCHI PIASTRE
PAGINA 72-93



**COPERTINE PER MURI
GRATICCIATE E COLONNE**
PAGINA 94-115



LITOLAND
PAGINA 116-127



LITOLAND



Joaquim Sas

Creare un dialogo con la natura e suggerire una connessione diretta e immediata tra spazio abitativo e paesaggio: sono queste le priorità che hanno guidato lo studio SAS. Il nostro impegno continua ad essere quello di progettare prodotti di alta qualità, tradizionalmente impiegati nei diversi ordini architettonici, ma interpretati in chiave contemporanea per integrarsi in molteplici strutture e vari contesti. I prodotti SAS sono ideali per mantenere lo spirito originario e peculiare di ogni casa, pur modernizzandola. L'Italia, culla dell'arte e guida architettonica per la moda di ogni epoca, sta dimostrando di essere ancora il luogo nel quale le energie positive della storia ritrovano, attingendo dal proprio passato, continue innovative risorse e soluzioni abitative. Un onore che attraverso l'utilizzo dei prodotti SAS sono orgogliosi di fare un po' mio, nel vedere le bellissime realizzazioni che anche questo book 2009 propone a tutti voi.

Joaquim Sas
Titolare di SAS Prefabricados de Hormigón SA



Michele Larcher

Dal 2003 ad oggi il fatturato SAS è esploso in maniera esponenziale, fino a raggiungere gli attuali € 1.500.000,00. Sono stati i clienti stessi, soddisfatti della qualità e della bellezza dei risultati ottenuti a trasmettere la carica ai venditori della nostra rete commerciale; persone fortemente motivate che giorno dopo giorno toccano con mano le performance dei prodotti SAS e li propongono con entusiasmo. 550 clienti rivenditori SAS con le loro esposizioni di prodotto e il fascino di innumerevoli soluzioni SAS nei diversi cantieri d'Italia, sono i nostri migliori biglietti da visita. Potrei dire che avverto l'esplosione di una SAS Vogue. Sì, perché i materiali SAS vestono le case e li ripropongono come un riflesso della personalità dei proprietari. Qualcosa di unico, proprio come accade per l'acquisto di un capo di alta moda, ma nel caso di SAS, una moda senza tempo e senza confini. Una certezza assoluta di qualità, durata e valore. Un piacere che non ha prezzo.

Michele Larcher
Importatore esclusivo SAS per l'Italia



BA



BALAUSTRE

PAGINA 6-71



Le Balaustre sono forme d'architettura senza tempo. Ideate dai romani oltre 2000 anni fa a scopo di recinzione sono state riprese, nei secoli successivi, come elementi protettivi e decorativi in innumerevoli opere architettoniche di immenso valore artistico. Per lungo tempo le Balaustre sono state realizzate in materiali naturali resistenti come il marmo e la pietra.

Oggi SAS è l'unica azienda in Italia che fornisce Balaustre in calcestruzzo non armato.

È attraverso l'innovativa tecnologia di compattazione e vibrazione utilizzata durante la lavorazione che si ottengono manufatti indistruttibili in tempi di produzione veloci e dalla messa in opera rapida.

Le Balaustre SAS sono prodotti evoluti dal fascino intramontabile.

BALAUSTRE





HOTEL PALACE

DESENZANO - BRESCIA

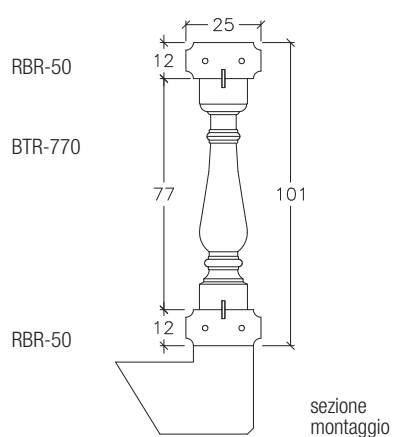

Il "Palace Hotel", inaugurato nel gennaio 2008, è situato dinanzi alle incantevoli sponde del lago di Garda, nella cittadina di Desenzano. Le grandi terrazze panoramiche sono coronate con le balaustre SAS che valorizzano lo stile e l'eleganza dell'intero edificio.

*Arch. Stefano Spaziani
Abaco Engineering S.r.l.
Progettista dell'hotel*



La balaustra è stata tinteggiata dopo il montaggio.





CASA DEL PRINCIPE

MUGGIA - TRIESTE

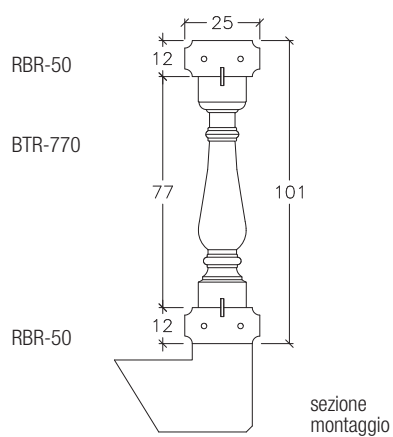





RESIDENZA AVGVSTAE

BASSANO DEL GRAPPA - VICENZA

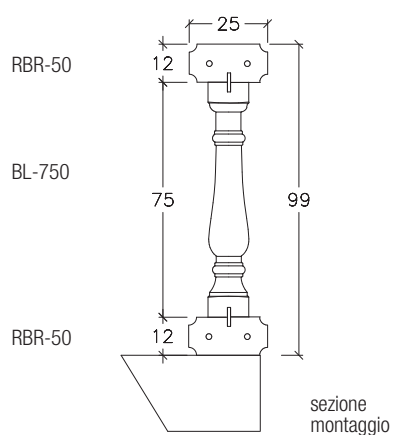

*Perché ammirare le regge quando invece
possiamo abitarle e lasciare che ad ammirarle siano gli altri?*

ARTECASA - progetta, costruisce e vende
Progettista: Mauro Buggin - Cassola (VI)



La balastra è stata tinteggiata dopo il montaggio.



HOTEL PREIDLHOF

NATURNO - BOLZANO

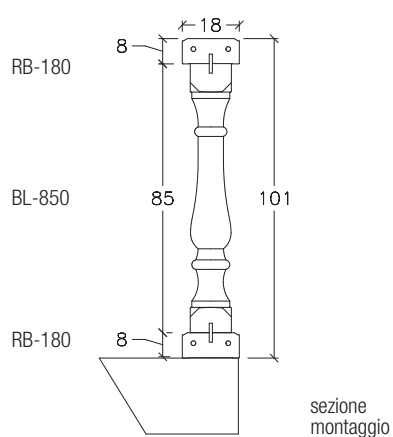





VILLA CORSINI

PONTE SAN MARCO - BRESCIA

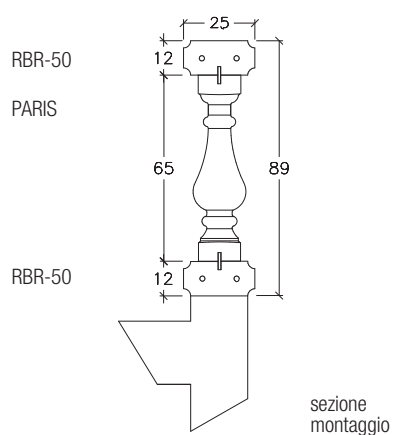





VILLA RANGONI MACCHIAVELLI

SPILAMBERTO - MODENA

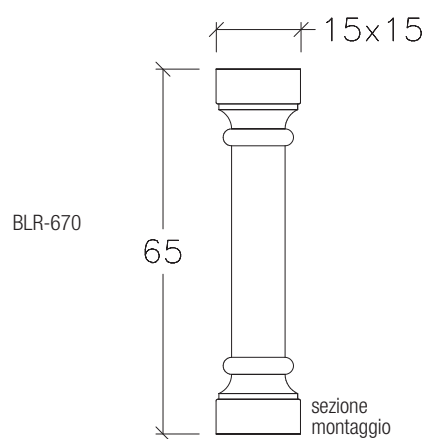





GRAND HOTEL SAVOIA

GENOVA

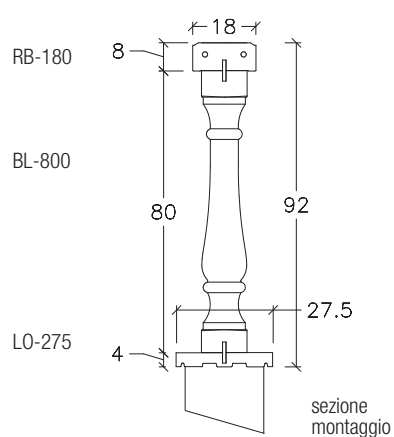

C'era la necessità di realizzare un nuovo "punto di vista" sul porto antico e sulla Lanterna che ne è il simbolo. Ora l'Hotel, dalla sua posizione di privilegio, può vantare una delle più belle terrazze genovesi.

*Michele Larcher
Importatore SAS*



La balaustra è stata tinteggiata dopo il montaggio.





CASA CAGNIN LUCIANO

SAN DONÀ DI PIAVE - VENEZIA

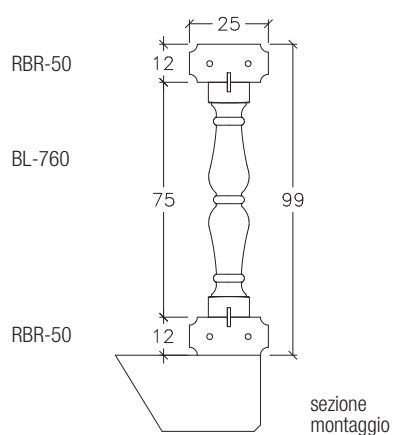





CENTRO COMMERCIALE

FOIANO DELLA CHIANA - AREZZO

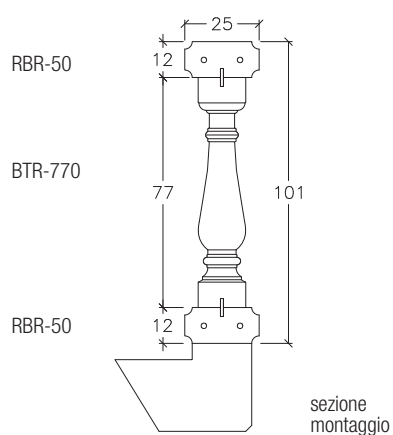





CONDOMINIO

ALBENGA - SAVONA

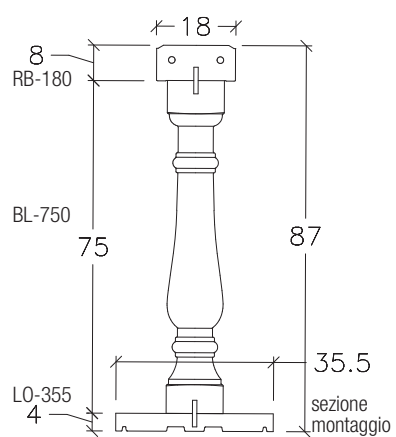





VILLA BONIFAZI

REPUBBLICA DI SAN MARINO

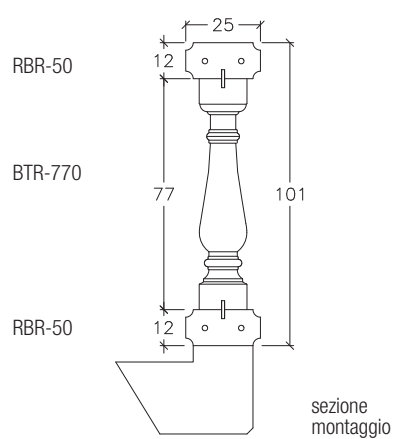

La balastra è stata tinteggiata dopo il montaggio.





VILLA CITRACCA

SAN BARONTO – PISTOIA

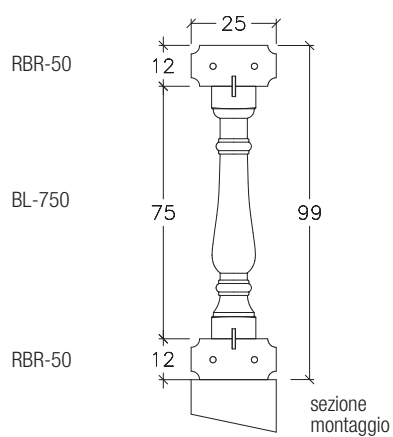





CASA JANSEN

LANA - BOLZANO

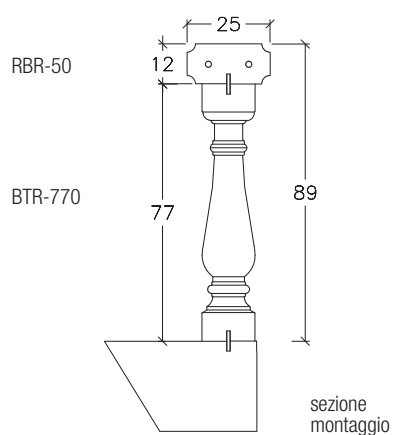





SEDE RARO HAUS

VANDOIES - BOLZANO

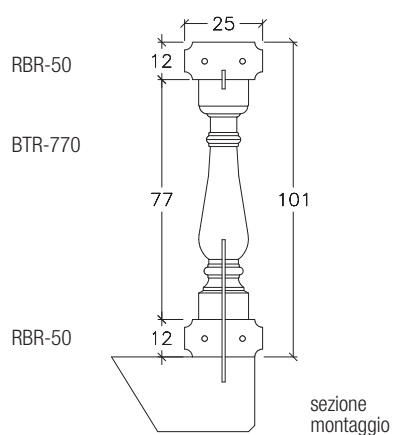

Volevamo una soluzione in stile classico e le balaustre SAS hanno rappresentato la miglior scelta per fare da protezione e al tempo stesso abbellire logge e balconi di un edificio CasaClima. Curate nei dettagli, facili da montare, esteticamente eccellenti, sono in grado di dare quel valore aggiunto indispensabile, soprattutto in presenza di particolari vincoli architettonici.

*Roland Raffin
Amministratore di Raro Haus*



La balaustra è stata tinteggiata dopo il montaggio.



www.raro-haus.it





VILLE VANZINI

GORLA MAGGIORE - VARESE

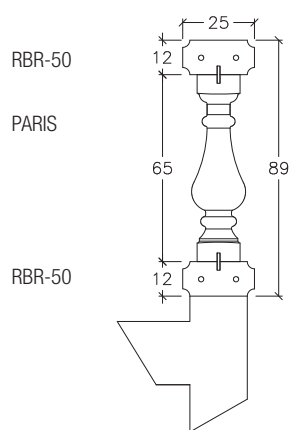

Volevo dare un tocco caratteristico alla mia proprietà, per sentirla mia in tutti i sensi. Ho deciso di utilizzare un manufatto che mi permettesse di essere in prima linea nel progetto. Ho installato personalmente le balaustre. È stato facile e divertente. Il risultato è eccellente e ne sono orgoglioso.

*Gerry Vanzini
Proprietario delle ville*



La balastra è stata tinteggiata dopo il montaggio.





IMMOBILIARE SORIM

CASTELLETTO SOPRA TICINO - NOVARA

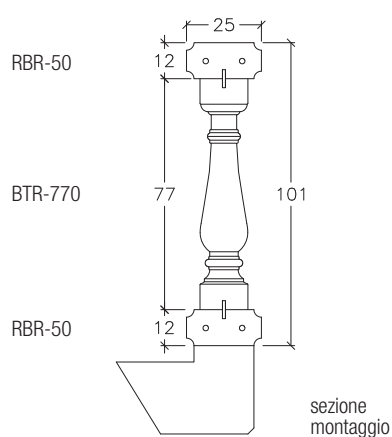

L'accostamento di corrimano rettilinei RBR-50 e corrimano curvi RBR-300R (diametro interno cm 300 - standard) alla balastra serie 770 ha permesso all'impresa di posa e messa in opera Zucchi di Castelletto Sopra Ticino la perfetta realizzazione di un perimetro di terrazze e logge a pianta ellittica.

*Michele Larcher
Importatore SAS*







VILLA RAPALLO

RAPALLO - GENOVA

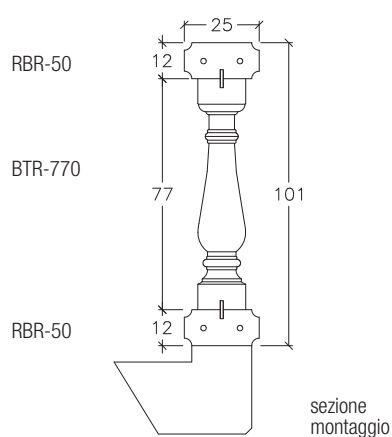

I proprietari di questa splendida terrazza a picco sul golfo di Portofino hanno scelto come rifinitura un sistema di balaustre SAS per armonizzare l'edificio con le ville storiche circostanti. Dopo un'attenta e scrupolosa ricerca hanno optato per le colonnine serie 770 che, prive di metallo all'interno, garantiscono la massima durabilità in ambienti salmastri.

*Salvatore Trovatore
Titolare della Rivendita Casa & Colore di Chiavari*







ISTITUTO SUORE PURIFICAZIONE DI MARIA SANTISSIMA

SAVONA

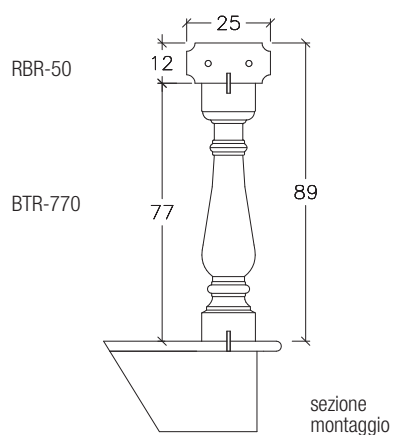

Per incorniciare il giardino della proprietà inserita nel complesso dell'Istituto Suore Purificazione Di Maria Santissima che si affaccia sulla nuovissima stazione marittima Costa Crociere di Savona, il proprietario ha scelto la soluzione serie 770 tronca. Lo spazio così ritagliato trova perfetta integrazione nel suo naturale contesto.

*Romolo Corsinovi
Titolare della Rivendita Edilco SAS*







VILLA BELVEDERE

TERRICCIOLA - PISA

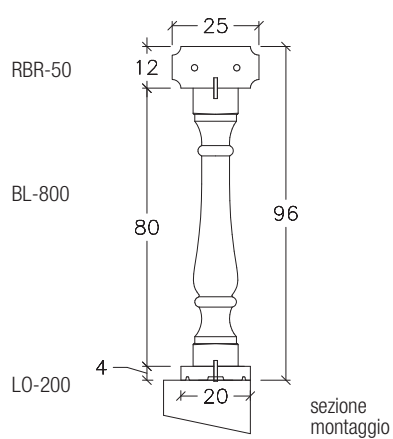

*Mi sembrava bella l'alta siepe di bacche rosse, ma ...
le balaustre SAS, come per incanto, hanno inondato tutto di luce e
di trasparenze. Ora posso davvero dire di vivere
al centro di un dolce paesaggio toscano.*

*Anna Gemma Zanaboni
Proprietaria della villa*







HOUSING “LE COLLINE”

PONTEDERA - PISA

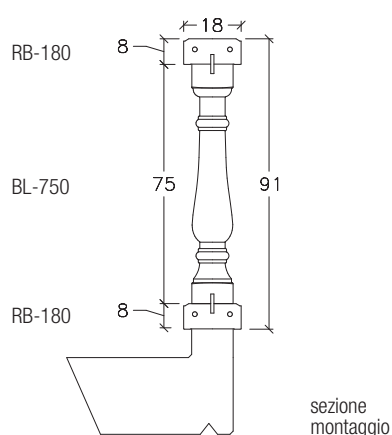

L'utilizzo delle balaustre SAS rappresenta l'elemento caratterizzante. Una sorta di 'divertissement' stilistico, nel quale elementi formali della classicità trovano una collocazione e una ragione all'interno di rigide logiche commerciali e normative. Questa scelta ci ha permesso di differenziarci dalla concorrenza e da una dinamica in cui è il prezzo a rappresentare il fattore decisivo di acquisto.

*Giuseppe Tozzi
Amministratore dell'Immobiliare costruttrice
Tozzi Costruzioni S.r.l. OSPEDALETTO – Pisa*





RECUPERO EDILIZIO VIALE MAZZINI

CASTIGLION FIORENTINO - AREZZO

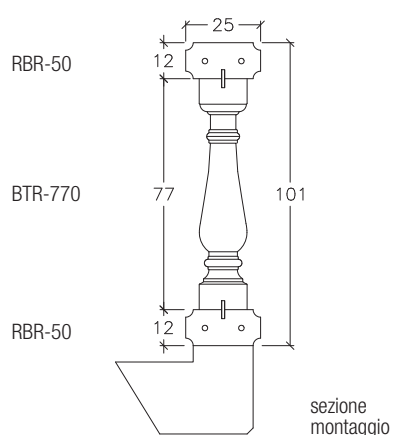

L'attenta analisi del progetto di ristrutturazione da parte del signor Fabio Martini, titolare dell'impresa immobiliare committente, sensibile agli aspetti connessi al contesto storico cittadino, è stata decisiva per la scelta delle balaustre SAS. L'effetto finale elegante, in perfetta armonia stilistica con l'ambiente circostante, ha inoltre contribuito a rendere più morbido lo stile austero della facciata.

*Arch. Susanna Poddi
Impresa Martini Srl realizzatrice dell'Immobilare*







HOTEL ITALIA

LIGNANO SABBIAADORO - UDINE

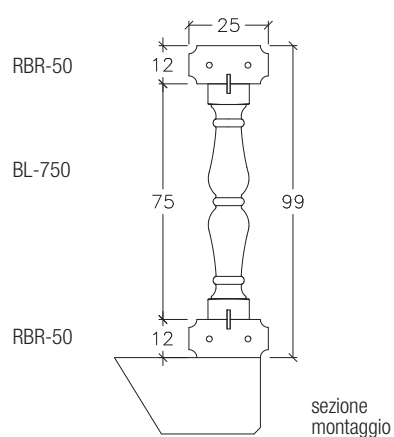

La balastra è stata tinteggiata dopo il montaggio.



CAMPING SIRMIONE

SIRMIONE - BRESCIA

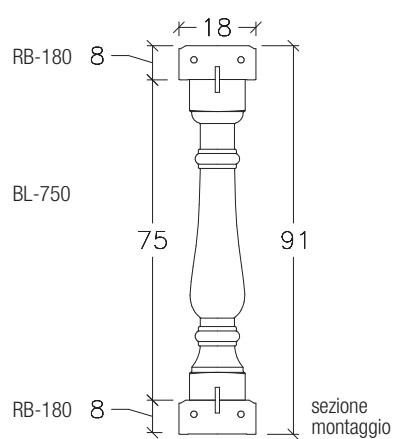

Le balaustre SAS sono state la risposta alla nostra ricerca di uno stile elegante e raffinato che potesse armoniosamente evidenziare la romantica atmosfera del lago.

*Famiglia Soardi
Proprietaria del Camping Sirmione*







VILLA PAGLIOLI

BOLOGNA

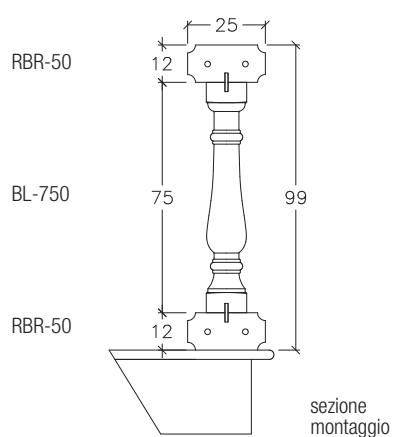

*Dovevamo collegare un'autorimessa di nuova costruzione
al lato posteriore di un edificio ottocentesco.
L'utilizzo delle balaustre SAS ha dato omogeneità ai due corpi inserendosi
gradevolmente nell'insieme degli spazi esterni.*

*Walter e Arturo Paglioli
Proprietari della villa*







HOTEL PORTA DEL SOLE

SOIANO DEL LAGO - BRESCIA

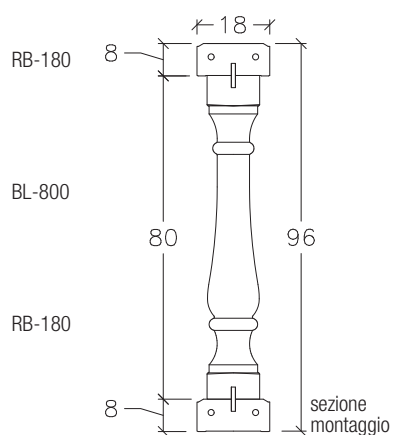

*Considerando la particolare posizione della struttura,
ho scelto le balaustre SAS, sia per la gradevolezza all'impatto ambientale,
sia per la loro sicurezza e solidità strutturale.
Sono di facile installazione e curate nei minimi dettagli.*

*Paolo Bertini
Proprietario dell'albergo*







WIESER BAU

CALDARO - BOLZANO

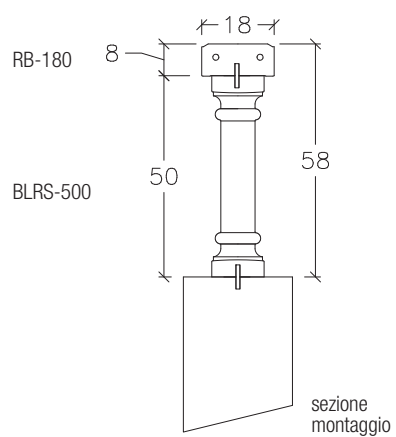





TORGGLKELLER
CALDARO - BOLZANO

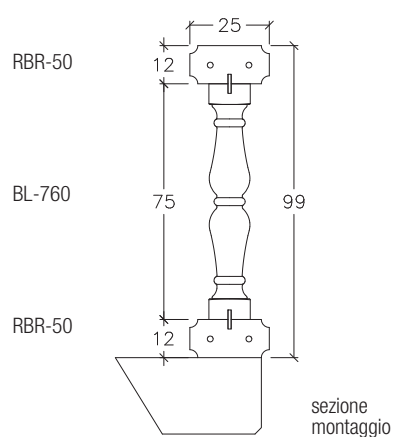

La colonnina a doppia pancia e la bifora sono elementi tipici dello stile dell'Oltradige, un miscuglio di arte gotica del nord Europa e rinascimentale del sud, in grado di convivere armoniosamente in diversi contesti architettonici e ambientali.

Michele Larcher
Importatore SAS





Hotel Sonnenberg



HOTEL SONNENBURG

MERANO - BOLZANO

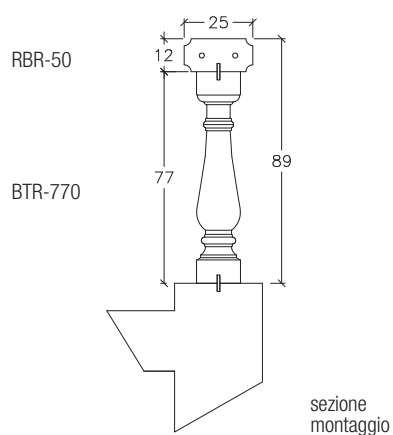





VILLA LANGES

EGNA - BOLZANO

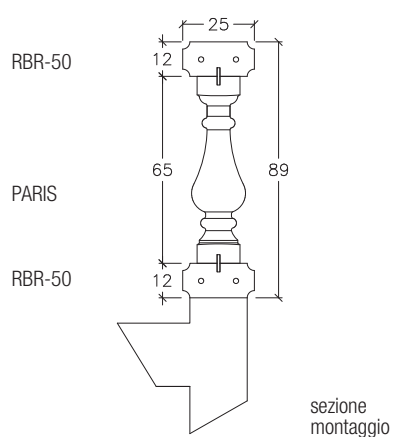

*La resa estetica che ho ottenuto con le balaustre SAS
è stata notevolmente superiore al prezzo pagato.*

*Roland Langes
Proprietario della villa*







HOTEL LE SOLEIL

JESOLO - VENEZIA

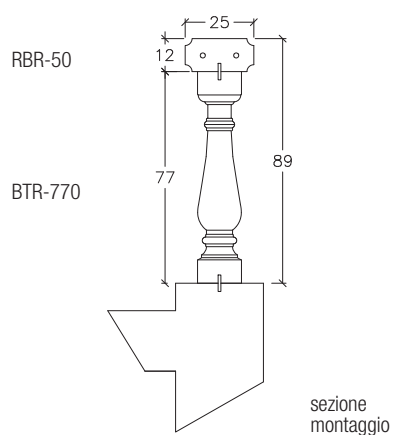





COGORNO

GENOVA

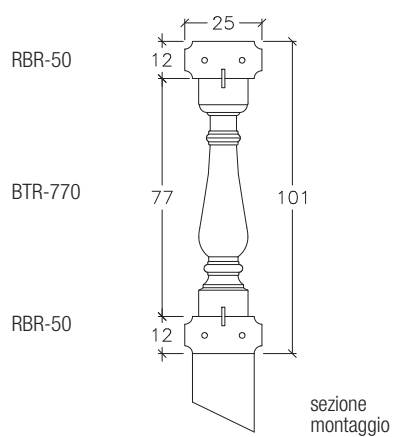

La balaustre è stata tinteggiata dopo il montaggio.





HOTEL CASA BIANCA AL MARE

JESOLO - VENEZIA

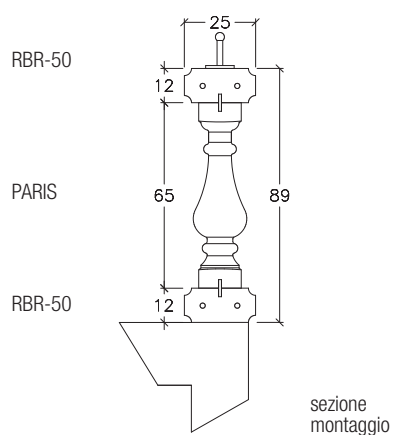

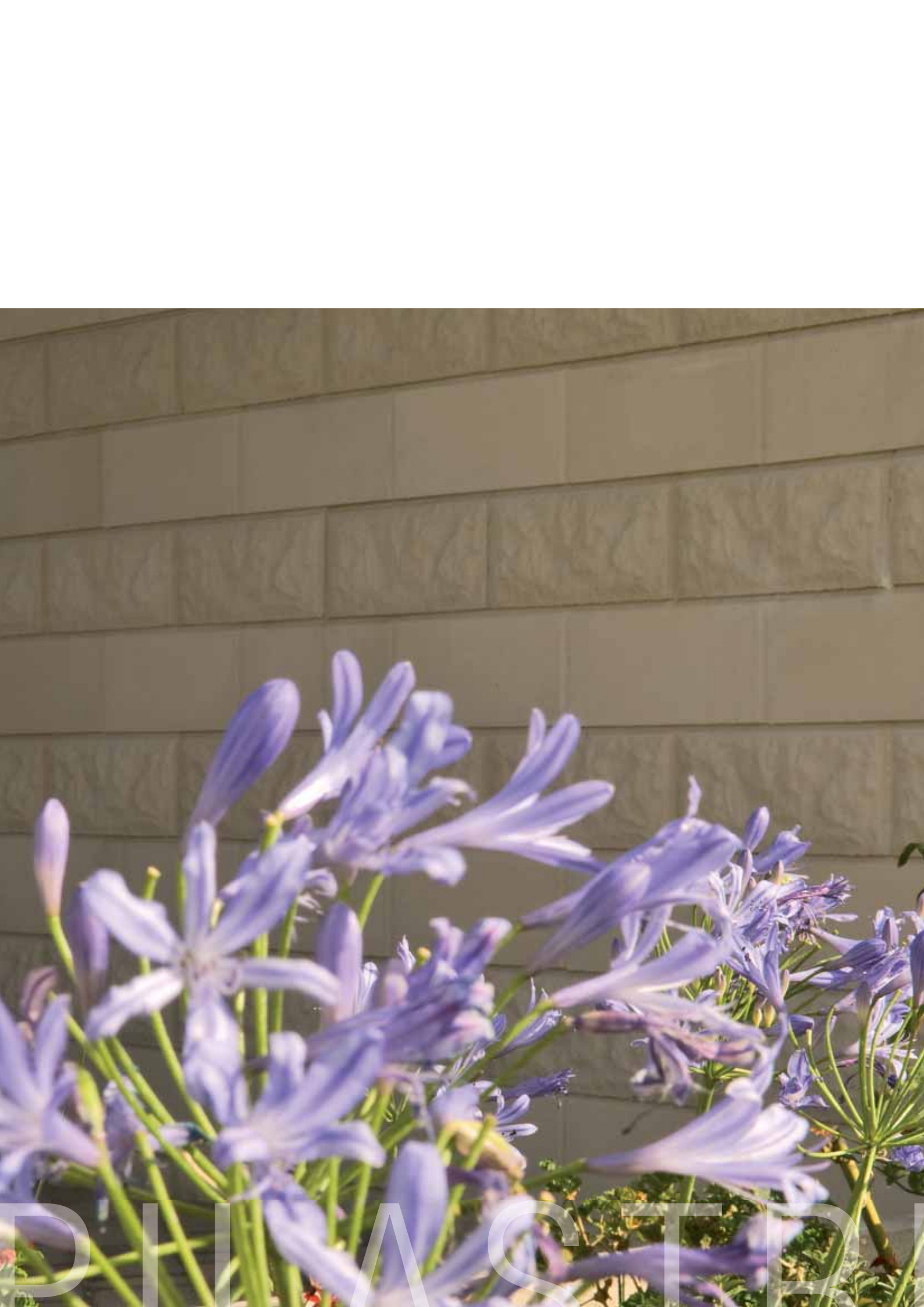

DUNA STEP



PILASTRI BLOCCHI PIASTRE

PAGINA 72-93



Esistono dettagli che possono cambiare il volto di un luogo o di un paesaggio, dargli calore e creare intorno ad esso un vortice di emozioni. Come succedeva con le suggestive recinzioni in pietra delle antiche ville. Oggi SAS con la gamma di Pilastri, Blocchi e Piastre offre un sistema di elementi prefabbricati, estremamente semplici da montare, ideali per creare strutture protettive

dall'impatto armonioso, rivestire serramenti e costruzioni preesistenti e rifinire in maniera elegante e uniforme ogni tipo di recinzione.

Quattro sono le varianti di finitura: il Bugnato, il Faccia Vista, l'Elite e il Borgoña.

Il materiale è calcestruzzo di cemento bianco o beige per ricordare i toni naturali e le indimenticabili atmosfere del marmo e della pietra.

BLOCCHI





CASA COLUCCI

ZONA AGRUZZO - BOLZANO



Pilastro Bugnato PIL-40 Bianco
Pilastro Bugnato PIL-30 Bianco
Blocco Bugnato BB-40 Bianco
Copertina a doppia pendenza AL-250 Bianca





CASA FERRETTI

CIVITANOVA - MACERATA



Pilastro Bugnato PIL-40 Bianco
Blocco Bugnato BB-40 Bianco
Copertina Bugnata CLAL-270 Bianca





VILLA

MARINA DI PIETRASANTA - LUCCA



Pilastro Bugnato PIL-40 Bianco
Blocco Bugnato BB-40 Bianco
Copertina Bugnata CLLO-270 Bianca
Sul balcone: Balaustra serie mista 770-750, con colonnina BL-760





CASA ARCH. LUIGI MUCCI

MORRO D'ALBA - ANCONA



www.neuearchitektur.com



Blocco bugnato BB-40 Bianco
Blocco Faccia Vista BLO-20 Bianco





NUOVO EDIFICIO "RUBINO"

ROVATO - BRESCIA

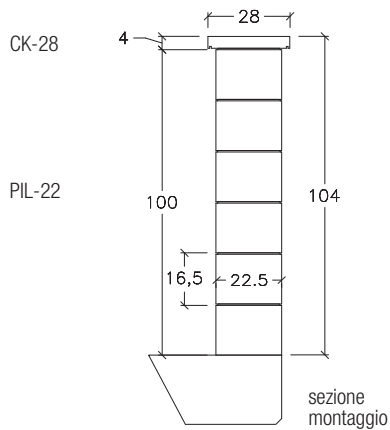

Il prodotto SAS si è rivelato perfetto per dare personalità ed eleganza al nostro progetto. Si è inserito nel contesto classico dell'intervento conferendo un tocco di modernità e stile e valorizzandone le finiture. È stato anche lo spunto per studiare una soluzione innovativa per la recinzione dei balconi.

Ottima versatilità operativa in fase di posa.

*Ing. Guido Lovo, Studio Lovo
Progettista dell'Immobile*







CASA GIANFELICI

SERRAPETRONA - MACERATA



Piastra Elite PLE-40



28v

PALAZZINA AREA EX STABILIMENTO FARFISA

CASTELFIDARDO - ANCONA



Blocco bugnato BB-40
Blocco bugnato di fine muro TBB-40
Copertina LO-250
Pilastro bugnato PB-30
Copripilastro piano CK-40
Ornamento sfera BD-220





VILLA RIPOSATI

PERUGIA

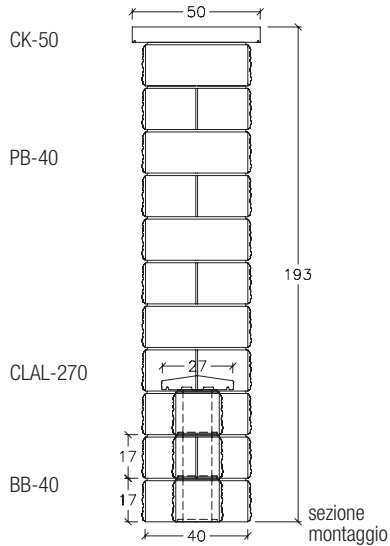

La finitura dei prodotti SAS è ottima. La recinzione, con la ringhiera in ferro battuto grezzo, si fonde armoniosamente con l'ambiente circostante.

*Stupefacente la rapidità di montaggio:
il fronte di 56 metri lineari è stato posato in due soli giorni lavorativi.*

*Luciano Riposati
Proprietario della villa*





43
Via Salsomaggiore

MAILBOX



CASA CORRADI

GAZOLDO DEGLI IPPOLITI - MANTOVA

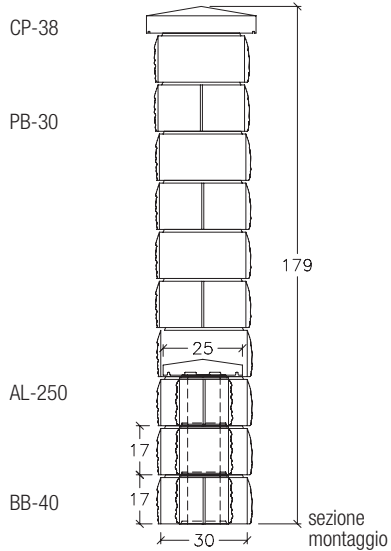

*Era da tempo che cercavo una recinzione bella dentro e fuori.
Finalmente con SAS l'ho trovata. Ha sempre un bell'aspetto ed è
facile da pulire. Sono molto soddisfatta di questa scelta, anche perchè,
con una spesa ragionevole, ho cambiato l'immagine della mia casa.*

*Marisa Corradi
Proprietaria della casa*







VILLA BROTTO

NOVENTA VICENTINA



Piastra bugnata PLB-400
Copertina bugnata piana CLLO-370

MIURI



GRAT



COPERTINE PER MURI GRATICCIATE E COLONNE

PAGINA 94-115



L'amore per i dettagli e lo studio intelligente dei particolari è la formula vincente di SAS. Nulla è lasciato al caso. Anche le Copertine per muri, ovvero le finiture protettive di muri e recinzioni, vengono prodotte in diverse sezioni, larghezze, materiali e colori e rappresentano una sorta di linea perfetta dell'eleganza.

Le Graticciate, in sei architetture diverse, sono

concepite non solo come elemento protettivo, ma per stupire e dare nuovo ritmo alle atmosfere di tutti i giorni.

Ma, a coniugare il gusto classico all'estro creativo della decorazione, sono le Colonne modulari ad incastro. Dall'utilizzo polifunzionale, sono in grado di creare armonia conferendo identità e qualità a ogni genere d'ambiente.

TTIC
CIATE





DIANA GRAND HOTEL

ALASSIO - SAVONA



*Volevo creare un ambiente accogliente riprendendo la tradizione del BERSO',
senza tralasciare il comfort offerto dall'innovazione tecnologica.*

*Con i prodotti SAS sono riuscito a coniugare
questi desideri e il risultato è evidente.*

*Giancarlo Quadrelli
Titolare del Diana Grand Hotel*



Colonna COL-33 Bianca
Piedestallo PED-33 Bianco
Colonnina BTR-770 Bianca
Corrimano RBR-50 Bianco
Corrimano RBR-12R di collegamento alla Colonna





CASA TOFFOLON GIANFRANCO

BIBIONE - VENEZIA



Pilastro Bugnato PIL-40 Bianco
Blocco Bugnato BB-40 Bianco
Graticciata C-242B Bianca
Copertina RL-B Bianca
Copertina AL-160 Bianca



Casino
Royal

Casino
Royal

MANUEL



CASINÒ ROYAL

VITTORIO VENETO - TREVISO



A Vittorio Veneto, città storica ai piedi delle Prealpi, nell'atmosfera affascinante delle sue bellezze naturali, ho curato l'aspetto estetico interno ed esterno del nuovo Casinò Royal.

Volevo dare all'edificio una forte personalità architettonica. Con i moduli SAS ho potuto realizzare sinuose colonne di cinque metri che svettano eleganti verso il cielo. Sembrano indossatrici che sfilano accompagnando i clienti nel magico mondo del gioco del Casinò.

*Maria dall'Anese
Artista e Designer*

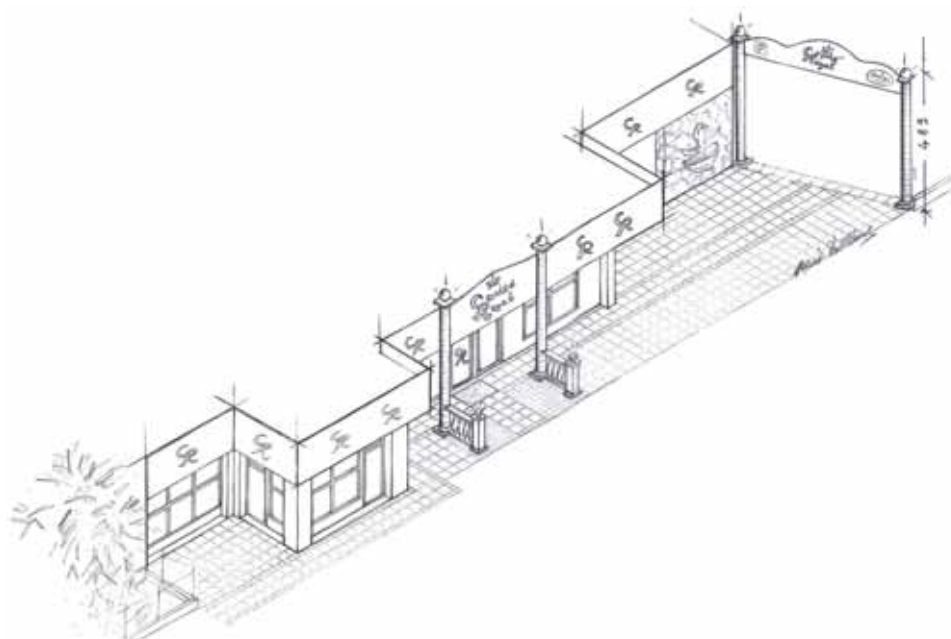

Colonna COL-33 Bianca
Piedestallo PED-33 Bianco
Balastra e Pilastro classico serie mista 770-750
Fioriera JC-500 Bianca

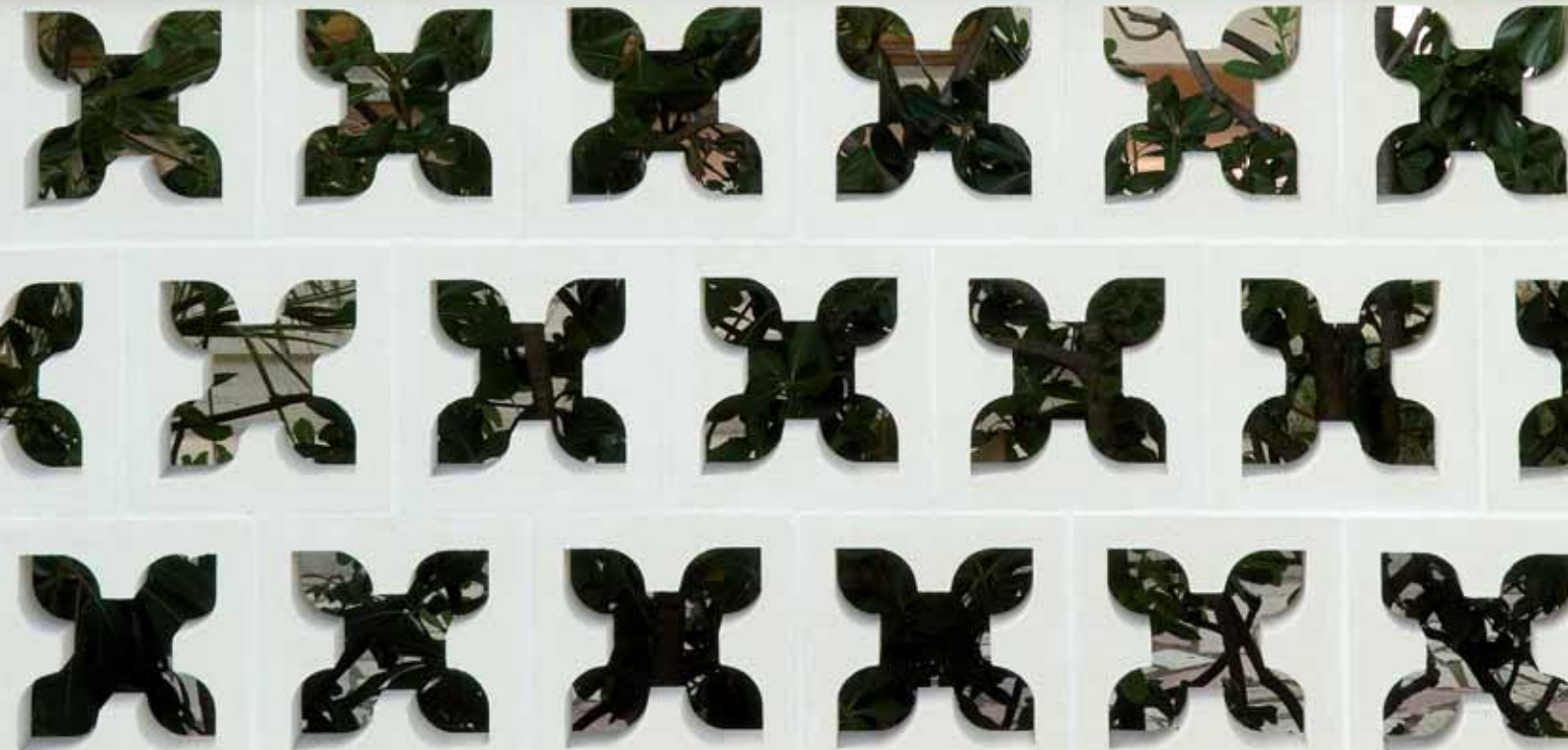



CASA GUGLIELMI

ROSIGNANO - LIVORNO



Graticciata C-255B Bianca
Copertina RL-B Bianca
Coprimuro LO-160 Bianco





VILLA FIORITA

CAIRO MONTENOTTE - SAVONA

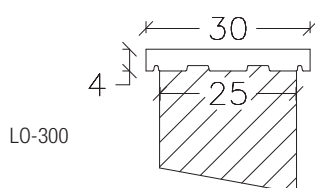

sezione
montaggio

Questa Villa storica dell'entroterra savonese è stata oggetto di una radicale e completa ristrutturazione. La proprietà ha voluto riproporre l'antico splendore della dimora adottando le più evolute tecnologie presenti sul mercato. Le copertine per muro LO-300 sono risultate essere la soluzione più idonea per guarnire i muri perimetrali.

Geometra Ferrando
Impresa Costruzioni Ferrando







VILLA FIORITA

CAIRO MONTENOTTE - SAVONA



La scelta di utilizzare materiali SAS nasce dall'esigenza di rivisitare in chiave moderna l'edificio, lasciando inalterate le peculiarità della tradizione locale. La gamma SAS, per la modularità dei prodotti e la perfetta resistenza al gelo, trova applicazione in vari contesti. In questo caso, per dividere la terrazza antistante il giardino, abbiamo scelto le graticciate mod. C-255B.

*Geometra Ferrando
Impresa Costruzioni Ferrando*



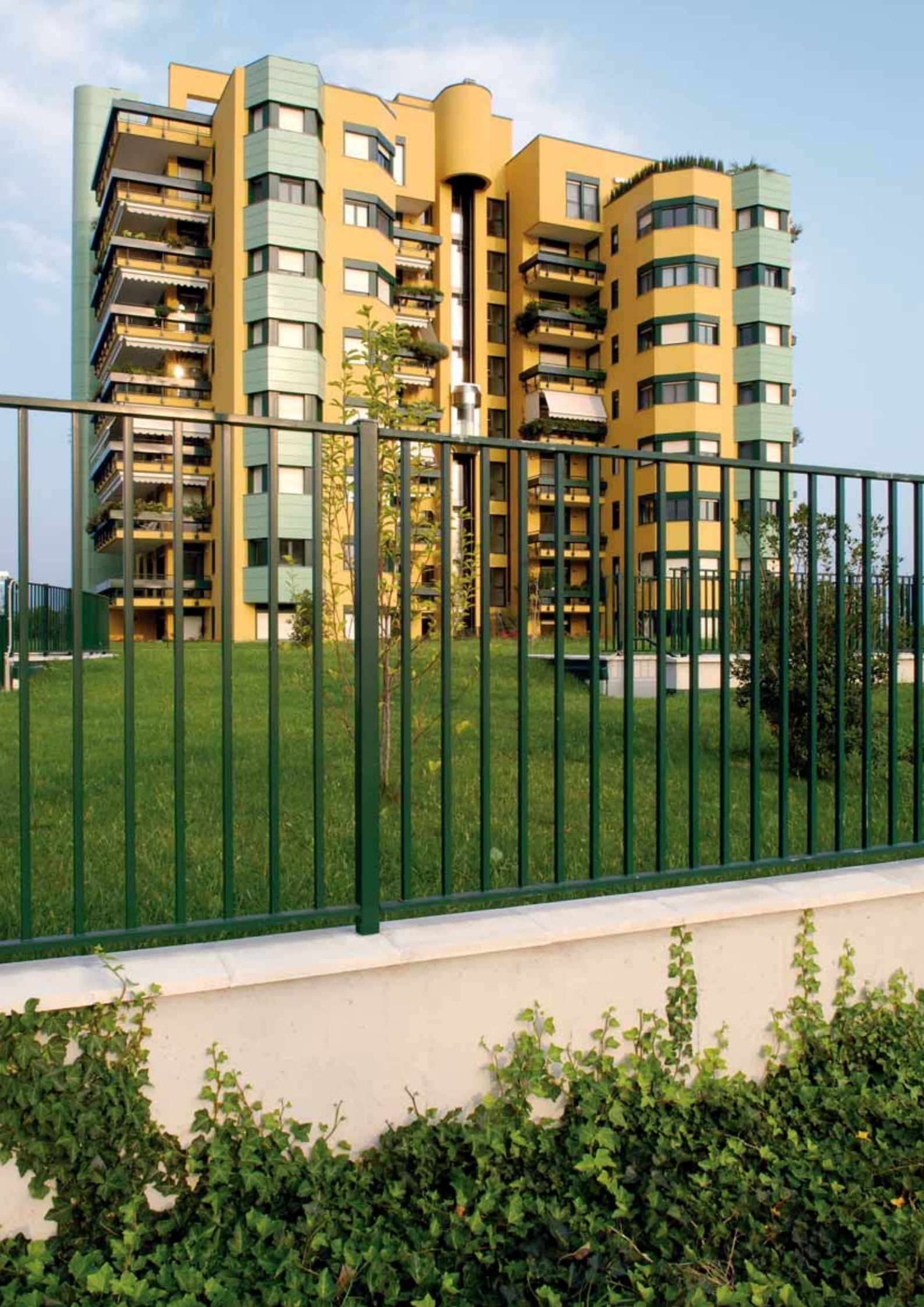



RESIDENZE MALASPINA PIRELLI RE AGENCY

PIOLTELLO - MILANO

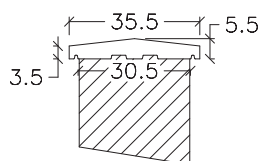

AL-355

sezione
montaggio







CAMPING SIRMIONE

SIRMIONE - BRESCIA

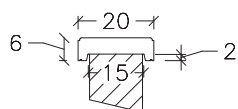

CU-200

sezione
montaggio



Copertina CU-200







HOTEL QUELLENHOF

VAL PASSIRIA - BOLZANO

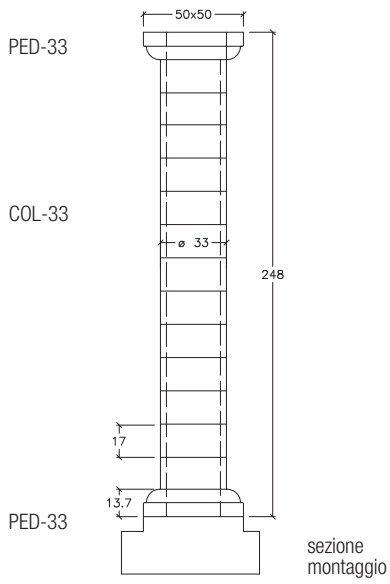





LITOLAND
PAGINA 116-127

LITOLAND



Litoland è la nuova linea SAS che parla il linguaggio della pietra, del legno e della natura. Una varietà di elementi in pietra artificiale e legno che riproducono in chiave innovativa i componenti base del patrimonio architettonico di ogni tempo. È la pietra in tutte le sue forme, cromatismi e varietà di utilizzo: murature, conci, angoli e pavimenti. È il legno che, in linea con uno spirito di semplicità e

di pulizia formale si inserisce, in piena sintonia, nell'ambiente circostante. Litoland, per la sua qualità e l'ampia flessibilità d'impiego è la soluzione all'avanguardia per contrastare la banalizzazione ed omologazione di molte costruzioni moderne. Dentro ogni dettaglio Litoland ci sono le radici della tradizione; per un vivere in perfetto equilibrio tra il piacere della memoria e i bisogni del presente.

LITOLAND

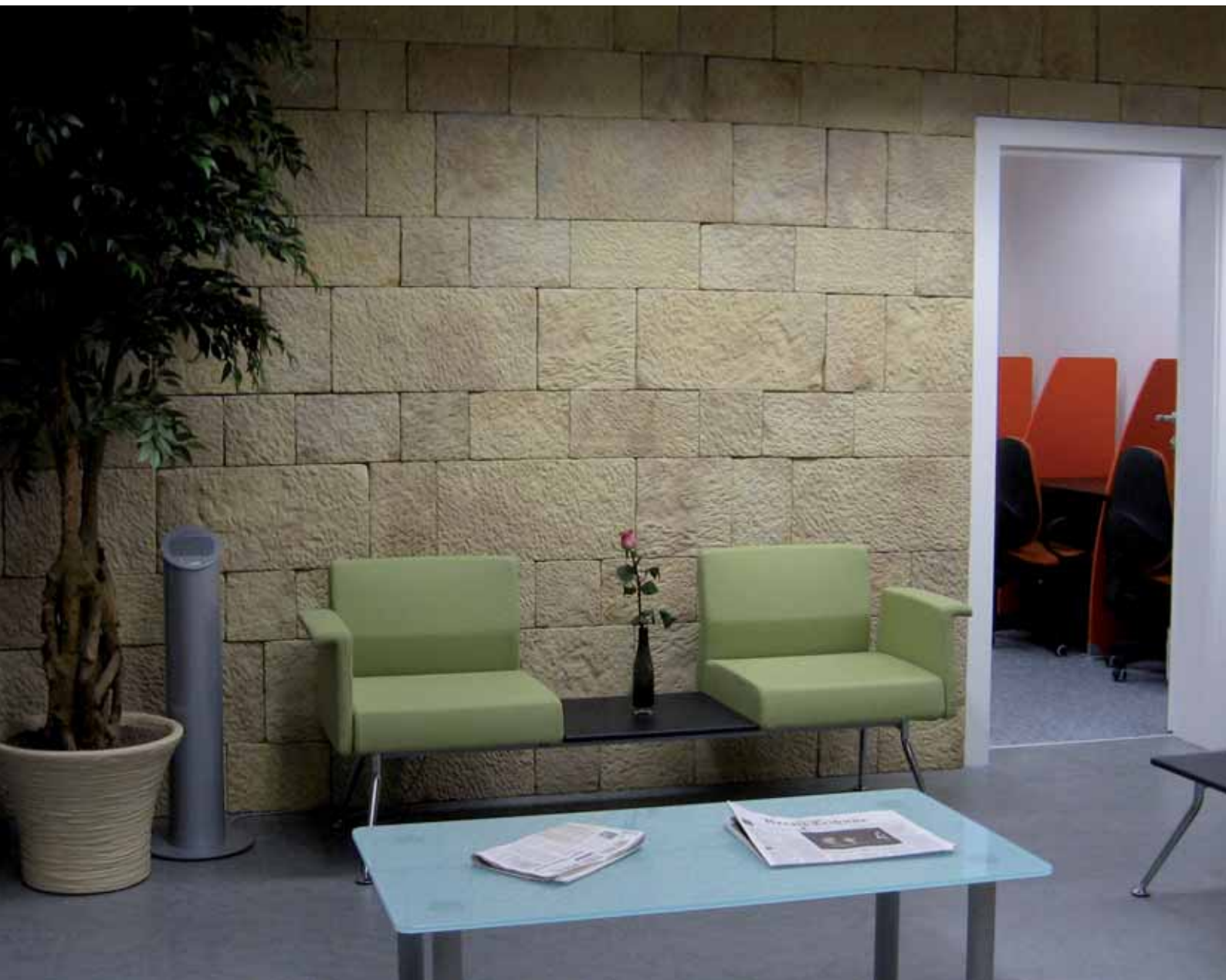



WALL STREET INSTITUTE

PRAGA - CECOSLOVACCHIA



Abbiamo studiato ogni dettaglio per la costruzione del primo Centro Linguistico "Wall Street" di Praga, coniugando armonia, visioni, voglia di vivere il nostro tempo; ma all'area di attesa di fronte alla reception mancava sempre qualcosa. In un solo giorno, con il rivestimento POBLET – la pietra ricostruita SAS – abbiamo trasformato un'anonima parete bianca in un muro secolare dalla magica atmosfera, dove lo sguardo dell'anima, circondato da vetro, acciaio e tecnologia, pare ritrovare calore, tradizione e sicurezza.

*Silvano Segala
Chief Executive Officer di Dolomia s.r.o.*



Rivestimento POBLET-2020 Albero
Rivestimento POBLET-2030 Albero
Rivestimento POBLET-2040 Albero
Rivestimento POBLET-3030 Albero
Rivestimento POBLET-3060 Albero







VILLA CAVAZZA

CASTELLARANO - REGGIO EMILIA



*È un prodotto innovativo, robusto e pratico, adatto ad ogni ambiente.
Quando il pavimento è sporco uso un po' di candeggina e in un baleno
torna come nuovo. Un perfetto connubio di praticità e bellezza.*

*Signora Cavazza
Proprietaria della Villa*



Lastra DOMUS-3030 Caliza
Lastra DOMUS-4530 Caliza
Lastra DOMUS-6030 Caliza





CANTINA SCHROTT

FRANGARTO - BOLZANO



Rivestimento POBLET-2020 Caliza
Rivestimento POBLET-2030 Caliza
Rivestimento POBLET-2040 Caliza
Rivestimento POBLET-3030 Caliza
Rivestimento POBLET-3060 Caliza





CANTINA MARTINI

CORNAIANO - BOLZANO



Modanatura MPOBLET Caliza
Lastra DOMUS-6030 Caliza





VILLA BRANDONI

CASTELFIDARDO- ANCONA



Sentiero DOMUSEND Caliza

Sede, Uffici tecnici, Consulenza e
Realizzazione progetti



Aldo Larcher
Importatore esclusivo SAS per l'Italia
I-39057 Appiano (BZ)
Via Artigiani, 5
tel. +39 0471 662486
fax +39 0471 661790
sas@aldolarcher.com
www.sas-sa.it

SAS Prefabricats de Formigó
E-08030 Barcelona
Pg. Torras i Bages, 106
tel. +34 93 345 8850
fax +34 93 346 1713
sas@sas-sa.com



Questo catalogo è stato realizzato grazie alla collaborazione dei nostri clienti.
È attraverso informazioni personali e per merito della vostra creatività che spesso
scopriamo nuove possibilità di utilizzo dei prodotti SAS. Se desiderate che il vostro
cantiere venga inserito nella prossima pubblicazione, potete inviare una foto con
il vostro nome e indirizzo a: sas@aldolarcher.com

Maurice Buggin

"People are strange" (The Doors)