

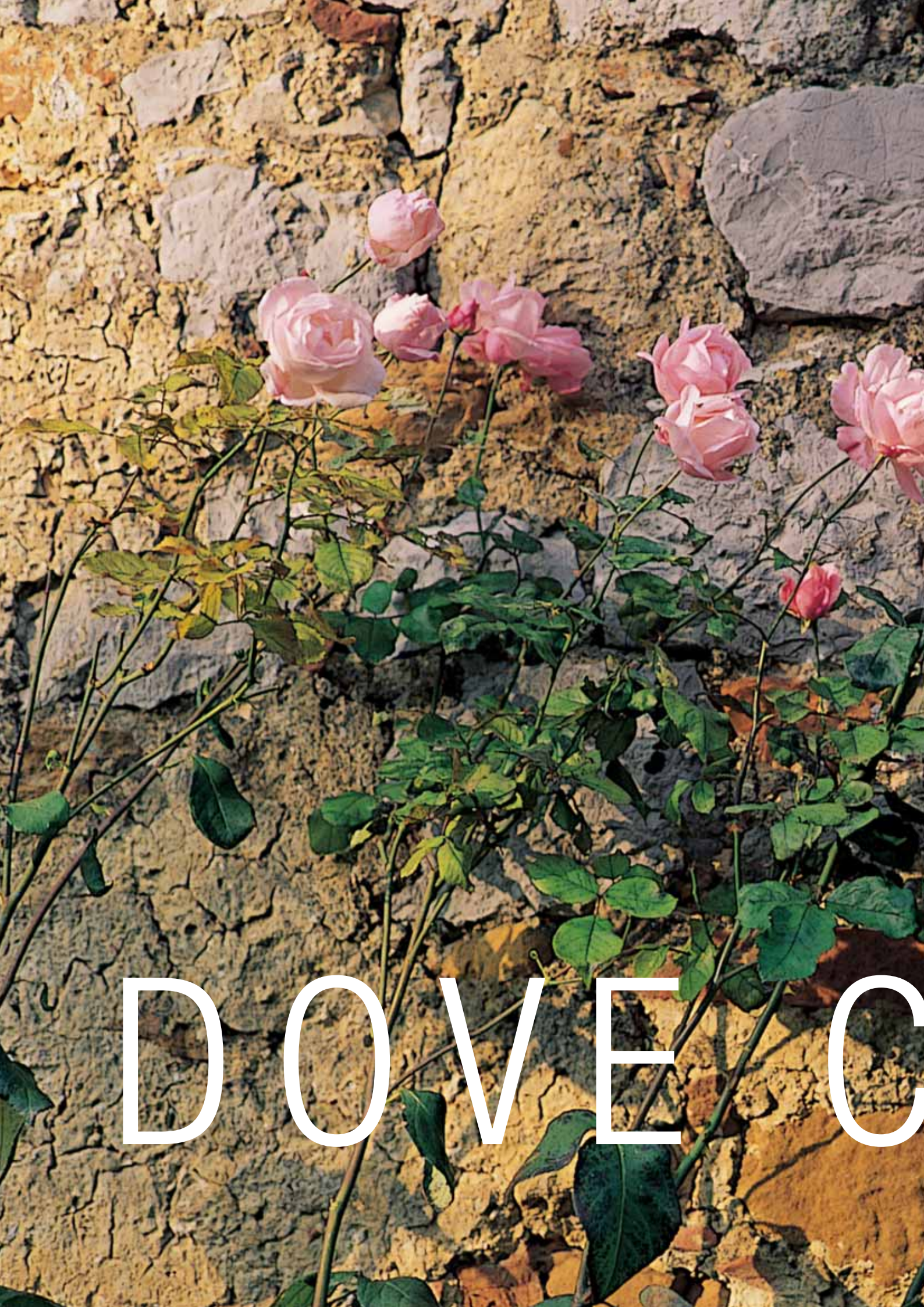

BOOK ITALIA 2008

BY ALDO LARCHER





D O V E C



È VITA



INDICE



BALAUSTRE

PAGINA 6-79



PILASTRI BLOCCHI PIASTRE

PAGINA 80-101



COPERTINE PER MURI GRATICCIATE E COLONNE

PAGINA 102-121



PIETRE RICOSTRUITE

PAGINA 122-125





Joaquim Sas

Quando penso alla sfida lanciata al mercato italiano assieme ad Aldo e Michele Larcher, la prima cosa che mi viene in mente è: i giochi sono fatti, la scommessa è vinta. Sì, perché quello che sta succedendo in Italia in termini di investimenti e risultati non trova eguali nel resto d'Europa. Al di là delle indiscutibili qualità dei nostri prodotti, l'esito positivo di questa esperienza sta soprattutto nell'energia e nella passione che anima il team Italia. Una squadra vincente che ha saputo dominare il business da veri campioni. Sono fiero di questa collaborazione e sono certo che il Gruppo Larcher abbia le risorse umane e gli strumenti di lavoro necessari per consolidare e continuare l'eccellente ritmo di crescita dei prodotti SAS in Italia. Un cordiale saluto da Barcellona.

Joaquim Sas
Titolare di SAS Prefabricados de Hormigón SA



Michele Larcher

Vorremmo che questo catalogo, frutto della collaborazione dei tanti partner e clienti privati che ci hanno mandato le loro foto e le loro dichiarazioni, diventasse per chi lo sfoglia una rivista di tendenza da cui trarre spunti ed emozioni. Lo spazio della casa per noi non è solo l'espressione primaria di un modo di vivere e dei valori ad esso legati, ma è anche il teatro di sperimentazione del design e il luogo dove si recupera la memoria delle proprie radici culturali. I prodotti SAS, ispirati alla spontaneità della natura, sono un modo nuovo ed originale di interpretare l'architettura quotidiana. Un tracciato compositivo che rielabora, in chiave personale, il rapporto con lo spazio che ci circonda. E lo rende unico, vivibile, nostro.

Michele Larcher
Importatore esclusivo SAS per l'Italia





BALAUSTRE

PAGINA 6-79



Le Balaustre sono forme d'architettura senza tempo. Ideate dai romani oltre 2000 anni fa a scopo di recinzione sono state riprese, nei secoli successivi, come elementi protettivi e decorativi in innumerevoli opere architettoniche di immenso valore artistico. Per lungo tempo le Balaustre sono state realizzate in materiali naturali resistenti come il marmo e la pietra.

Oggi SAS è l'unica azienda in Italia che fornisce Balaustre in calcestruzzo non armato. È attraverso l'innovativa tecnologia di compattazione e vibrazione utilizzata durante la lavorazione che si ottengono manufatti indistruttibili in tempi di produzione veloci e dalla messa in opera rapida. Le Balaustre SAS sono prodotti evoluti dal fascino intramontabile.

ALUSTRE





SEDE RARO HAUS

VANDOIES - BOLZANO

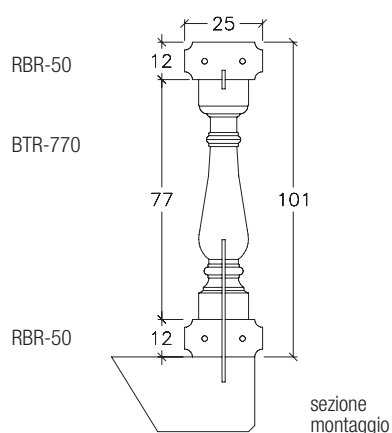

Volevamo una soluzione in stile classico e le balaustre SAS hanno rappresentato la miglior scelta per fare da protezione e al tempo stesso abbellire logge e balconi di un edificio Casa clima. Curate nei dettagli, facili da montare, esteticamente eccellenti, sono in grado di dare quel valore aggiunto indispensabile, soprattutto in presenza di particolari vincoli architettonici.

*Roland Raffin
Amministratore di Raro Haus*



La balastra è stata tinteggiata dopo il montaggio.



www.raro-haus.it





VILLE VANZINI

GORLA MAGGIORE - VARESE

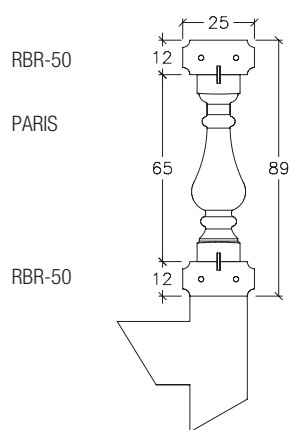

Volevo dare un tocco caratteristico alla mia proprietà, per sentirla mia in tutti i sensi. Ho deciso di utilizzare un manufatto che mi permettesse di essere in prima linea nel progetto. Ho installato personalmente le balaustre. È stato facile e divertente. Il risultato è eccellente e ne sono orgoglioso.

*Gerry Vanzini
Proprietario delle ville*



La balastra è stata tinteggiata dopo il montaggio.





IMMOBILIARE SORIM

CASTELLETTO SOPRA TICINO - VARESE

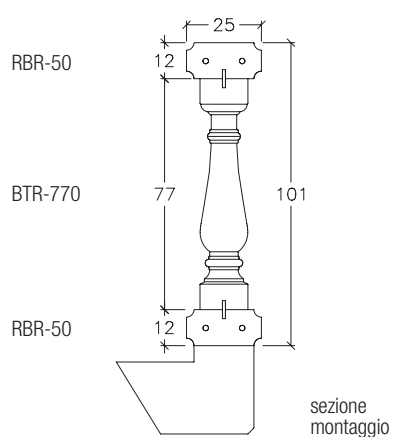

L'accostamento di corrimano rettilinei RBR-50 e corrimano curvi RBR-300R (Diametro interno cm 300 - standard) alla balastra serie 770 ha permesso all'impresa di posa e messa in opera Zucchi di Castelletto Sopra Ticino la perfetta realizzazione di un perimetro di terrazze e logge a pianta ellittica.

*Michele Larcher
Importatore SAS*



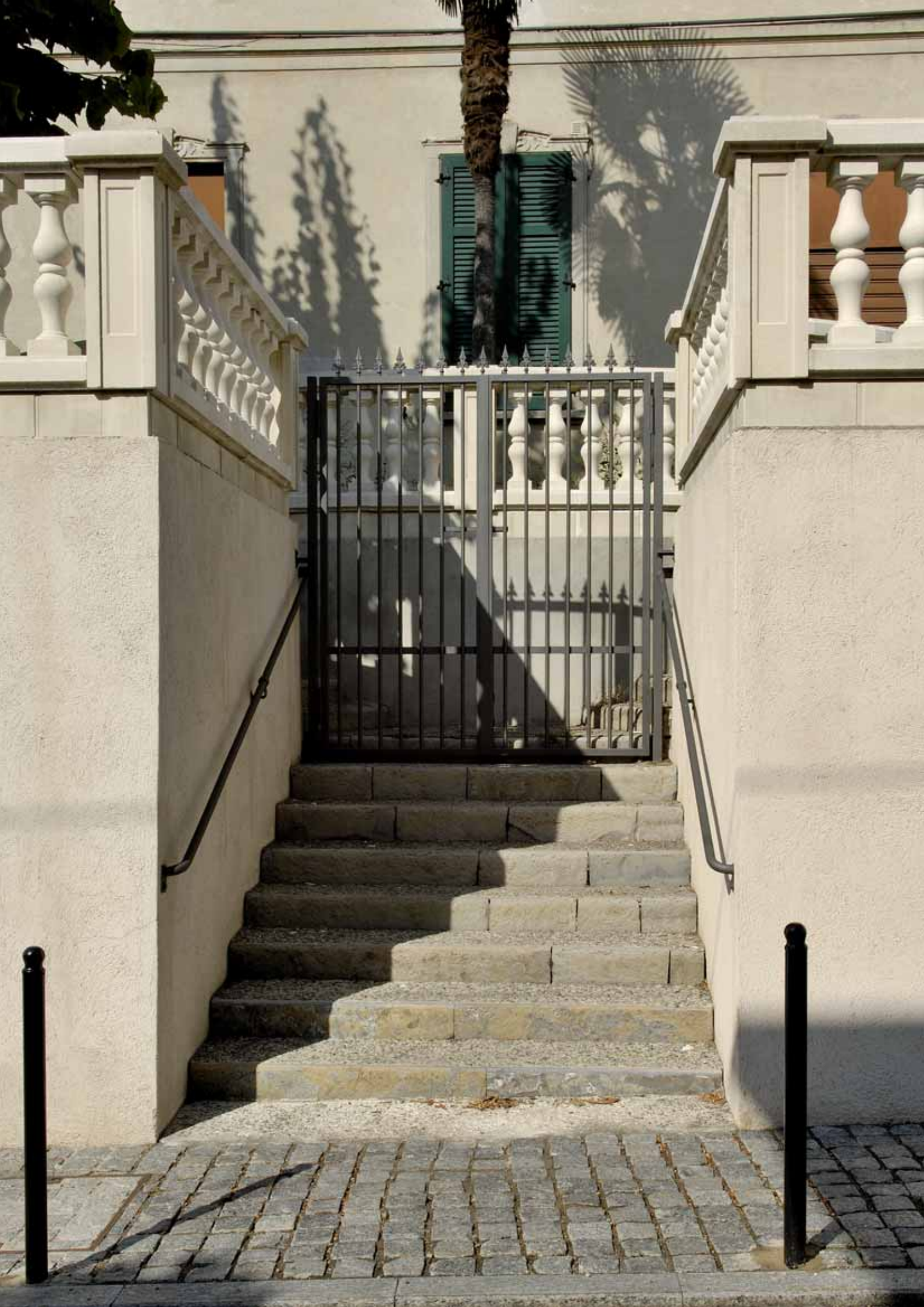



CIRCOLO FAMILIARE VERTEMATE

VERTEMATE - COMO

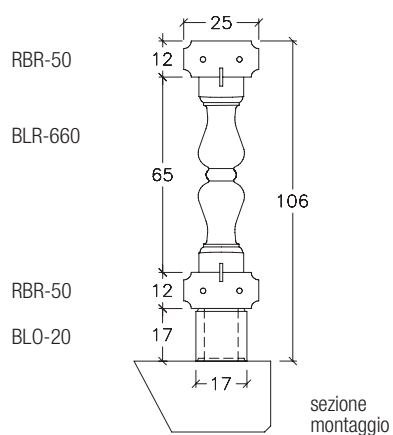





PALAZZO MILANO VIA TEODOSIO

MILANO

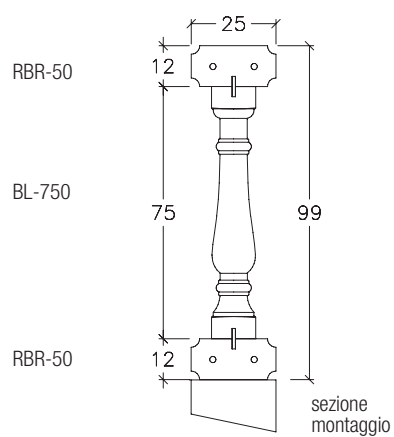





VILLA RAPALLO

RAPALLO - GENOVA

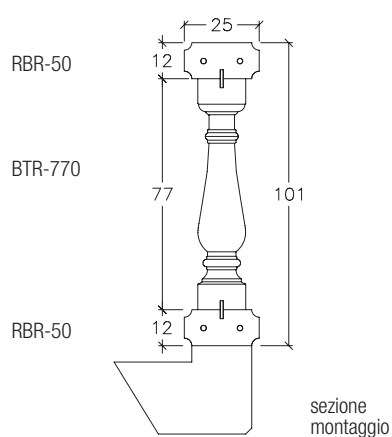

I proprietari di questa splendida terrazza a picco sul golfo di Portofino hanno scelto come rifinitura un sistema di balaustre SAS per armonizzare l'edificio con le ville storiche circostanti. Dopo un'attenta e scrupolosa ricerca, hanno optato per le colonnine serie 770 che, prive di metallo all'interno, garantiscono la massima durabilità in ambienti salmastri.

*Salvatore Trovatore
Titolare della Rivendita Casa & Colore di Chiavari*







ISTITUTO SUORE PURIFICAZIONE DI MARIA SANTISSIMA

SAVONA

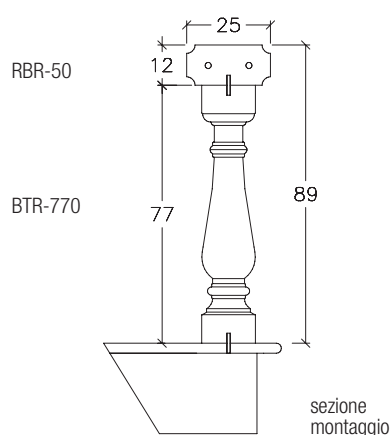

Per incorniciare il giardino della proprietà inserita nel complesso dell'Istituto Suore Purificazione Di Maria Santissima che si affaccia sulla nuovissima stazione marittima Costa Crociere di Savona, il proprietario ha scelto la soluzione serie 770 tronca. Lo spazio così ritagliato trova perfetta integrazione nel suo naturale contesto.

*Romolo Corsinovi
Titolare della Rivendita Edilco SAS*







VILLA BONATTI

CEPARANA - LA SPEZIA

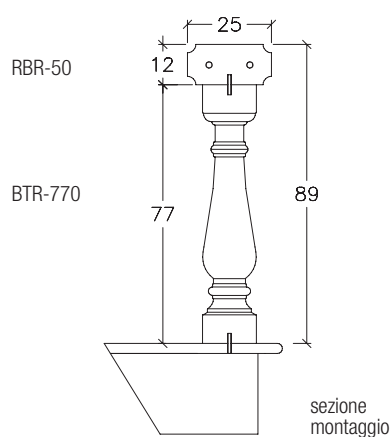

Lo spazio sul fronte dell'edificio è stato ampliato e livellato mediante la costruzione di un muro in pietra, secondo la tradizione ligure dei terrazzamenti, con copertina in pietra arenaria a livello del prato.

La balaustra scelta come parapetto è stata la BTR-770 che, con il corrimano RBR-50 rendeva possibile la continuità del paesaggio, delimitando con le sue linee aggraziate, lo spazio domestico.

*Studio Ass. Ghelfi Roberto e Scarponi Daniela Architetti
Responsabili del progetto di Sistemazione del giardino*







VILLA BELVEDERE

TERRICCIOLA - PISA

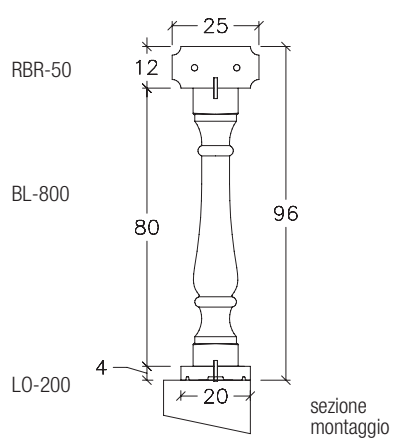

*Mi sembrava bella l'alta siepe di bacche rosse, ma ...
le balaustre SAS, come per incanto, hanno inondato tutto di luce e
di trasparenze. Ora posso davvero dire di vivere
al centro di un dolce paesaggio toscano.*

*Anna Gemma Zanaboni
Proprietaria della villa*







HOUSING “LE COLLINE”

PONTEDERA - PISA

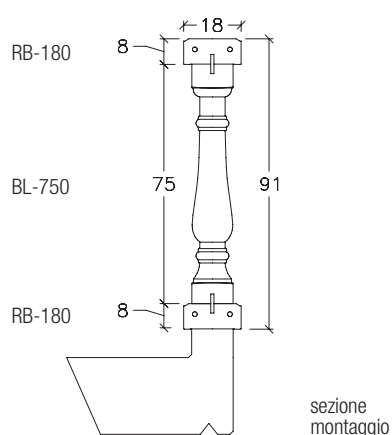

L'utilizzo delle balaustre SAS rappresenta l'elemento caratterizzante. Una sorta di 'divertissement' stilistico, nel quale elementi formali della classicità trovano una collocazione e una ragione all'interno di rigide logiche commerciali e normative. Questa scelta ci ha permesso di differenziarci dalla concorrenza e da una logica commerciale in cui è il prezzo a rappresentare il fattore decisivo di acquisto.

*Giuseppe Tozzi
Amministratore dell'Immobiliare costruttrice
Tozzi Costruzioni S.r.l. OSPEDALETTO – PISA*







VILLA

EMPOLI - FIRENZE

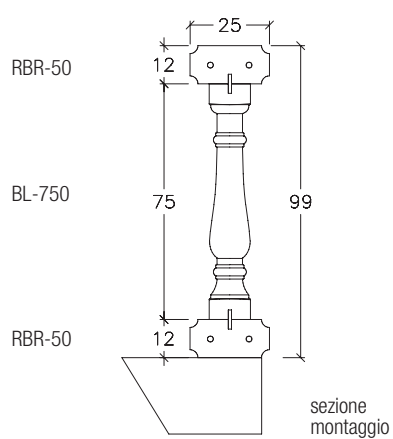

La balastra è stata tinteggiata dopo il montaggio.



RECUPERO EDILIZIO VIALE MAZZINI

CASTIGLION FIORENTINO - AREZZO

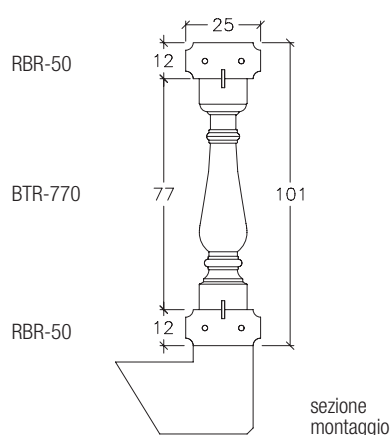

L'attenta analisi del progetto di ristrutturazione da parte del signor Fabio Martini, titolare dell'impresa immobiliare committente, sensibile agli aspetti connessi al contesto storico cittadino, è stata decisiva per la scelta delle balaustre SAS. L'effetto finale elegante, in perfetta armonia stilistica con l'ambiente circostante, ha inoltre contribuito a rendere più morbido lo stile austero della facciata.

*Arch. Susanna Poddi
Impresa Martini Srl realizzatrice dell'Immobilare*







RESIDENCE “VILLA LUISA”

ASSISI - PERUGIA

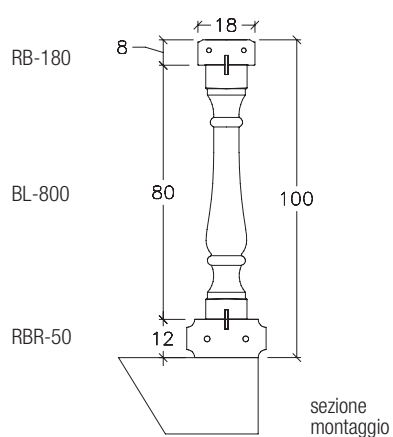

Le balaustre SAS sono in perfetta armonia con l'ambiente medievale della cittadina umbra. Hanno dato luce e bellezza, in modo semplice ed economico, a tutto il contesto architettonico, integrandosi con delicatezza nell'atmosfera del paesaggio.

*Maura Manini
Proprietario dell'immobile*





Mercedes



RESIDENZA PONTENUOVO

RAVENNA

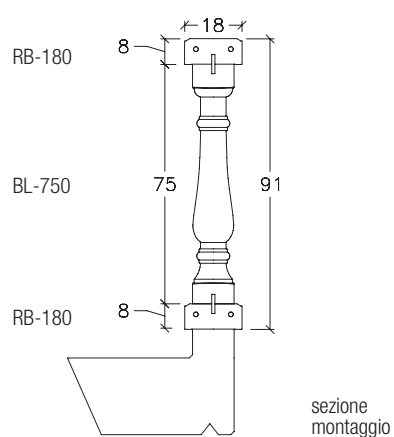





HOTEL ITALIA

LIGNANO SABBIAADORO - UDINE

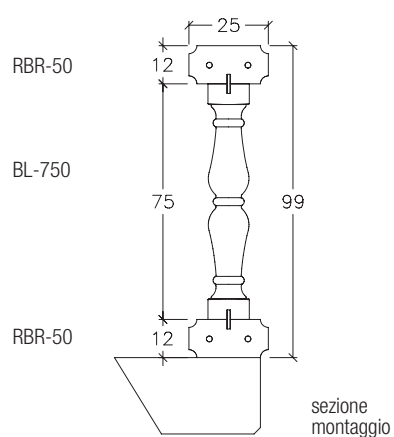

La balaustra è stata tinteggiata dopo il montaggio.



CAMPING SIRMIONE

SIRMIONE - BRESCIA

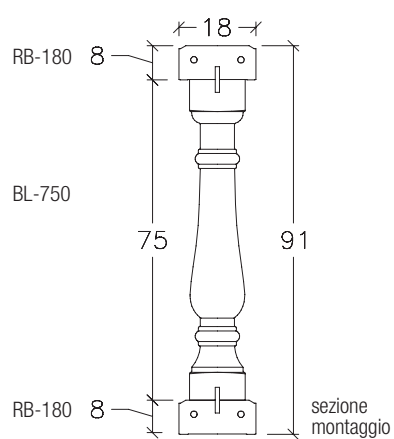

Le balaustre SAS sono state la risposta alla nostra ricerca di uno stile elegante e raffinato che potesse armoniosamente evidenziare la romantica atmosfera del lago.

*Famiglia Soardi
Proprietaria del Camping Sirmione*







HOTEL VENETO

ROMA

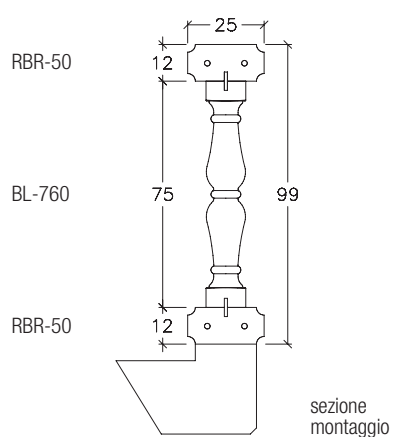

*Durante la ristrutturazione dell'albergo, in aprile 2006,
mi sono rivolto all'unica azienda, la SAS, in grado di consegnare
70 metri lineari di balaustra in due settimane dall'ordine.*

*Maurizio Mencucci
Proprietario dell'albergo*







PIAZZA CARLO GIORDANO

CAPALBIO - GROSSETO

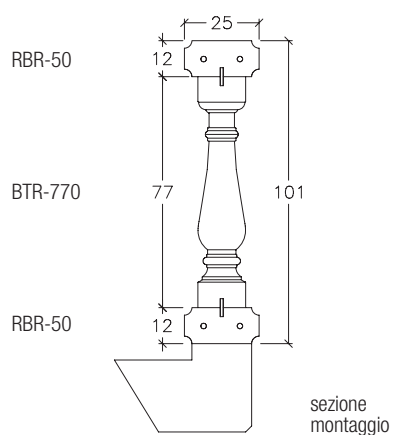





VILLA PAGLIOLI

BOLOGNA

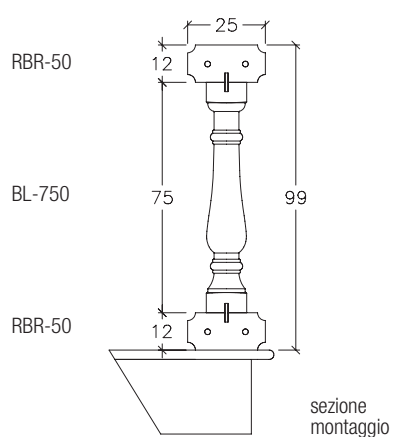

*Dovevamo collegare un'autorimessa di nuova costruzione
al lato posteriore di un edificio ottocentesco.
L'utilizzo delle balaustre SAS ha dato omogeneità ai due corpi inserendosi
gradevolmente nell'insieme degli spazi esterni.*

*Walter e Arturo Paglioli
Proprietari della villa*







HOTEL PORTA DEL SOLE

SOIANO DEL LAGO - BRESCIA

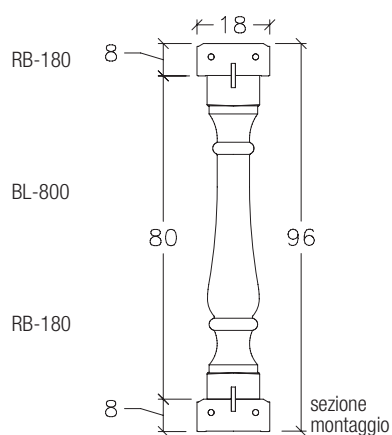

*Considerando la particolare posizione della struttura,
ho scelto le balaustre SAS, sia per la gradevolezza all'impatto ambientale,
sia per la loro sicurezza e solidità strutturale.
Sono di facile installazione e curate nei minimi dettagli.*

*Paolo Bertini
Proprietario dell'albergo*







WIESER BAU

CALDARO - BOLZANO

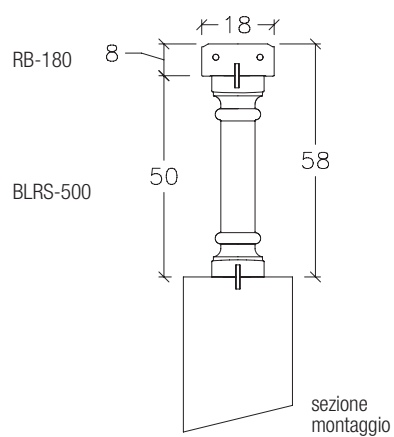





TORGGLKELLER

CALDARO - BOLZANO

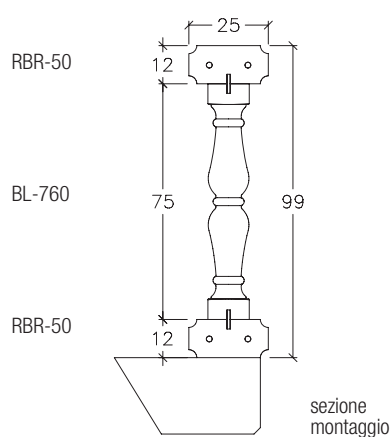

La colonnina a doppia pancia e la bifora sono elementi tipici dello stile dell'Oltradige, un miscuglio di arte gotica del nord Europa e rinascimentale del sud, in grado di convivere armoniosamente in diversi contesti architettonici e ambientali.

Michele Larcher
Importatore SAS

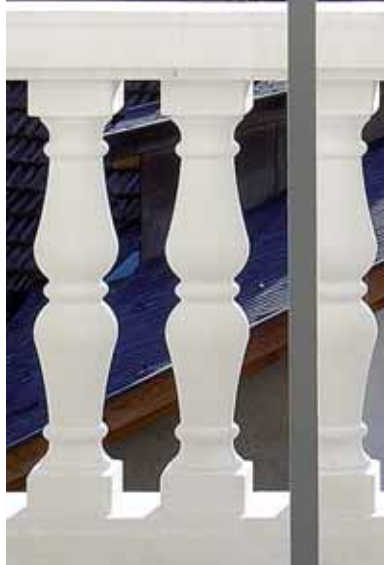



CASA GIULIANI DIETER

APPIANO - BOLZANO

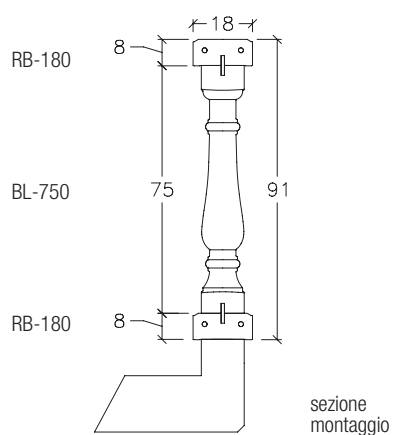



Hotel Sonnenberg



HOTEL SONNENBURG

MERANO - BOLZANO

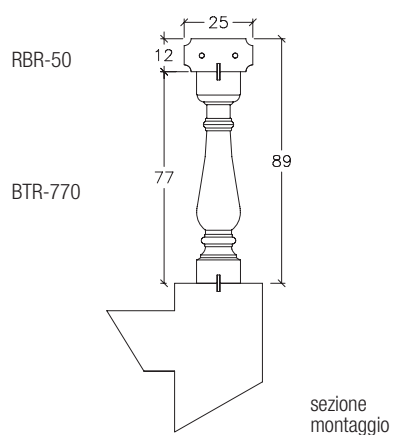





VILLA LANGES

EGNA - BOLZANO

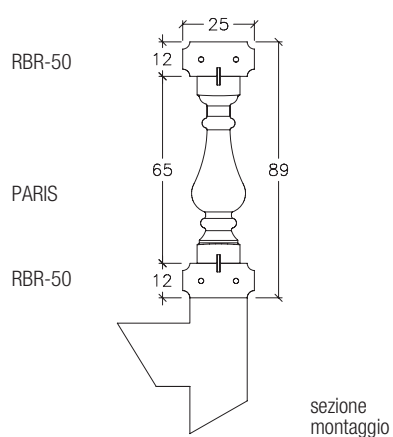

*La resa estetica che ho ottenuto con le balaustre SAS
è stata notevolmente superiore al prezzo pagato.*

*Roland Langes
Proprietario della villa*







CASA BETTIN - CASTEL BELFORT

SPORMAGGIORE - TRENTO



Corrimano in pietra di Verona. Colonnine Art. BL-600, BL-800





CASA PELUCCHI

CREMONA

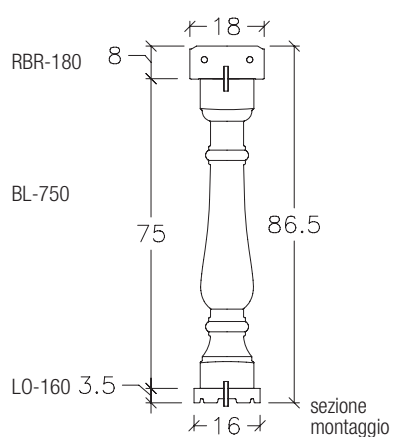

La balaustra SAS si addice a ogni genere di abitazione, non solo alle residenze signorili. L'armonia delle forme classiche ne consente l'utilizzo in qualsiasi tipo di contesto architettonico e contribuisce sempre alla sua valorizzazione.

*Roberto Castrezati
Agente di zona SAS*







VILLA DELUCCHI

LAVAGNA - GENOVA

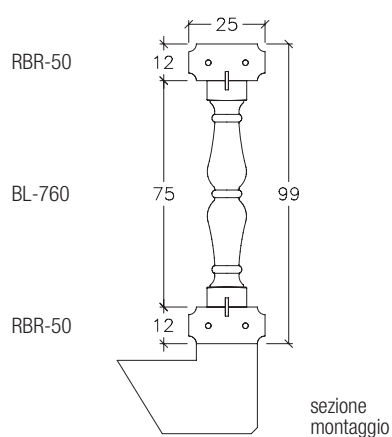

Questo edificio d'inizio secolo, restaurato nel corso del 2005/2006, si trova nella zona nobile della cittadina di Lavagna (GE). La proprietà ha deciso di utilizzare colonne SAS modello BL-606 per i terrazzi e di restaurare i prospetti originali abbinando colonnine a elementi in ferro battuto. La direzione lavori ha ridisegnato e modificato le balaustre del lastrico solare impiegando la soluzione LANZAROTTO, caratterizzata dall'utilizzo di zoccolature e corrimano mod. RBR-50, pilastri PBR-750, copri pilastri CBR-300 e colonnine BL-760. Il risultato è semplicemente sorprendente.

*Michele Larcher
Importatore SAS*



La balastra è stata tinteggiata dopo il montaggio.





VILLAGGIO COLOMBO

PONSACCO - PISA

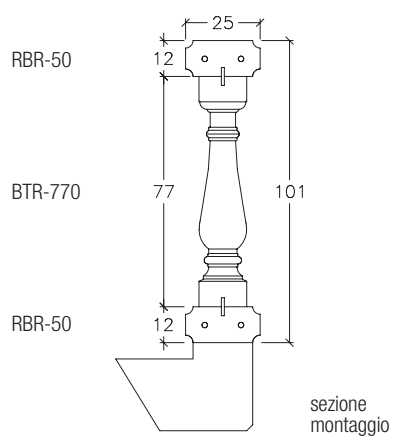





HOTEL LE SOLEIL

JESOLO - VENEZIA

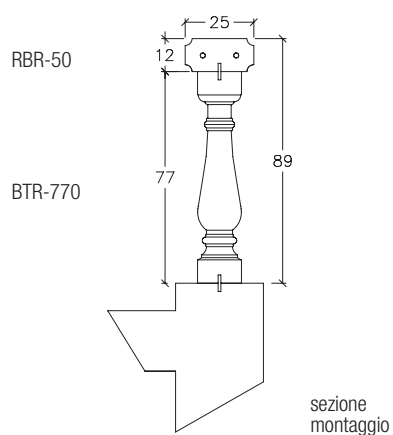





HOTEL CENTRALE

MEZZOCORONA - TRENTO

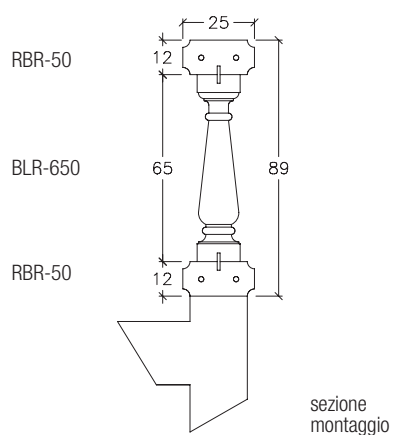





VILLA BORGHETTO

TRENTO

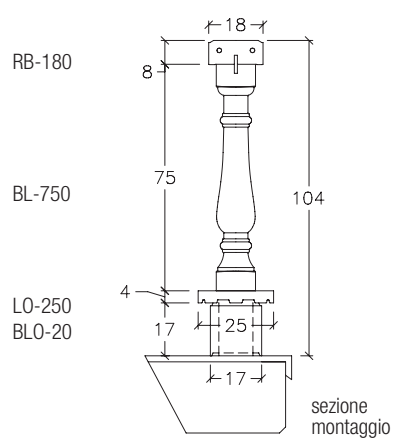





RAGONE

MOLARE - ALESSANDRIA

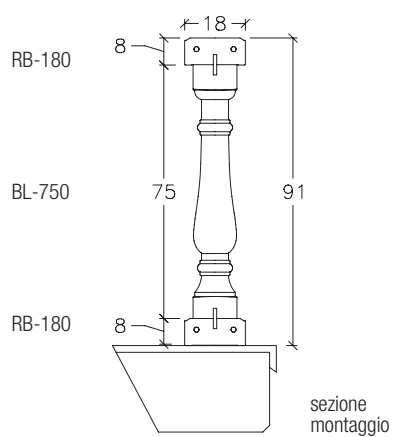

La balastra è stata tinteggiata dopo il montaggio.





COGORNO

GENOVA

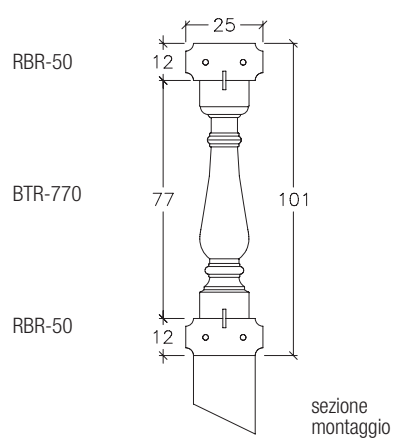

La balaustra è stata tinteggiata dopo il montaggio.





HOTEL CASA BIANCA AL MARE

JESOLO - VENEZIA

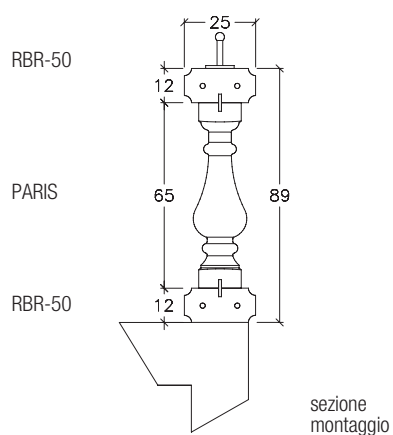



*Prêt-à-porter, Mare nostrum 2004
veduta della mostra,
balcone, 2 cannocchiali,
49 cartoline incorniciate cm 17x21,5 ciascuna
pittura murale*

CENTRO PER L'ARTE CONTEMPORANEA "LUIGI PECCI"

PRATO

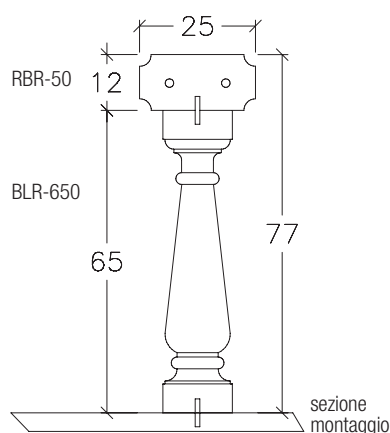

PRÊT-À-PORTER, 2004 LUCA VITONE
BALAUSTRA SERIE 650 TRONCA.

Prêt-à-porter è il progetto di Luca Vitone, ideato appositamente per lo spazio Lounge al piano terra del Centro per l'Arte Contemporanea Luigi Pecci.

Al centro della ricerca specificatamente concettuale eppure di grande efficacia visiva dell'artista vi è il complesso rapporto tra i luoghi e le modalità di rappresentarli, tra l'esplorazione personale, diretta della realtà e quella mediata, diffusa dei "luoghi comuni", tra la concreta materialità delle cose e le tracce che esse imprime nella nostra memoria.

Il progetto per il Centro per l'Arte Contemporanea Luigi Pecci ha previsto un radicale intervento ambientale da parte dell'artista: la trasformazione della lunga parete sinuosa nel rilievo cartografico di una costiera; la presentazione su quella stessa parete di una singolare mappa d'Italia costruita attraverso immagini tipiche raccolte in ogni regione; l'inserimento nel centro dello spazio di una balaustra divisoria e di vari cannocchiali da cui poter vedere e ricomporre le immagini realizzate dall'artista ripercorrendo il paese da nord a sud.

Volevo un prodotto funzionale, che rendesse l'idea di affacciarsi sul balcone di un Belvedere, per osservare, attraverso un cannocchiale, ambientazioni di villaggi tipicamente italiani. Con la balaustra SAS ho realizzato perfettamente il mio progetto artistico.

Luca Vitone
Artista



*Prêt-à-porter, 2004
Museo Pecci, Prato
veduta della mostra,
balcone, 2 cannocchiali, diapositive,
cm 1600x550x170*



PILA STRE



PILASTRI BLOCCHI PIASTRE

PAGINA 80-101



Esistono dettagli che possono cambiare il volto di un luogo o di un paesaggio, dargli calore e creare intorno ad esso un vortice di emozioni. Come succedeva con le suggestive recinzioni in pietra delle antiche ville. Oggi SAS con la gamma di Pilastri, Blocchi e Piastre offre un sistema di elementi prefabbricati, estremamente semplici da montare, ideali per creare strutture protettive

dall'impatto armonioso, rivestire serramenti e costruzioni preesistenti e rifinire in maniera elegante e uniforme ogni tipo di recinzione.

Quattro sono le varianti di finitura: il Bugnato, il Faccia Vista, l'Elite e il Borgoña.

Il materiale è calcestruzzo di cemento bianco o beige per ricordare i toni naturali e le indimenticabili atmosfere del marmo e della pietra.

B
I
O
C
C
H





CASA GIANFELICI

SERRAPETRONA - MACERATA



Piastra Elite PLE-40

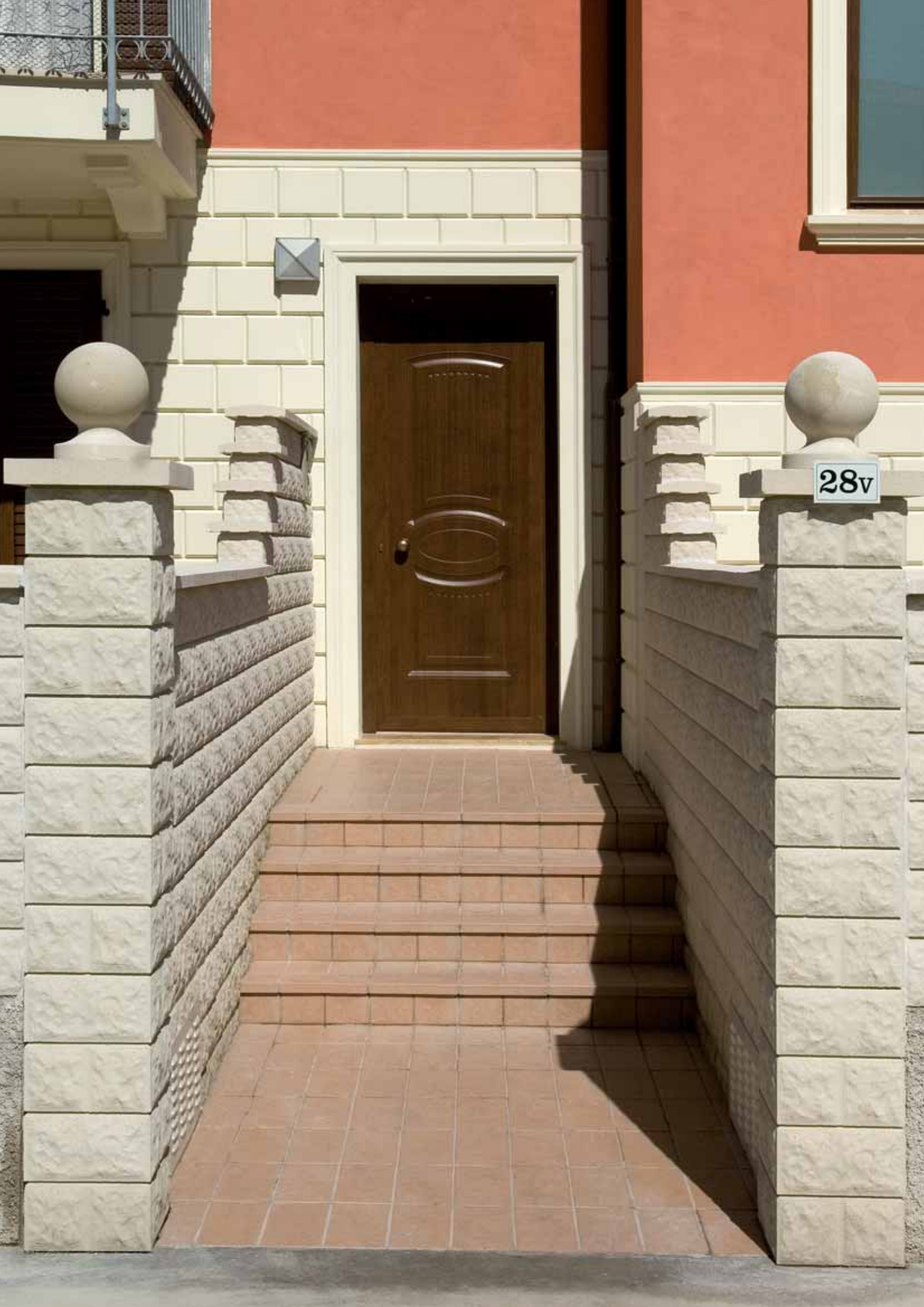

28v



PALAZZINA AREA EX STABILIMENTO FARFISA

CASTELFIDARDO - ANCONA



Blocco bugnato BB-40
Blocco bugnato di fine muro TBB-40
Copertina LO-250
Pilastro bugnato PB-30
Copripilastro piano CK-40
Ornamento sfera BD-220





VILLA RIPOSATI

PERUGIA

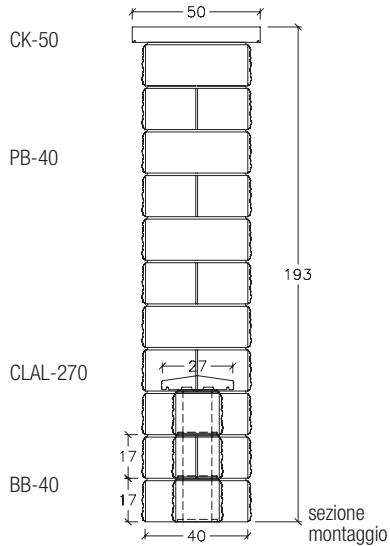

La finitura dei prodotti SAS è ottima. La recinzione, con la ringhiera in ferro battuto grezzo, si fonde armoniosamente con l'ambiente circostante.

*Stupefacente la rapidità di montaggio:
il fronte di 56 metri lineari è stato posato in due soli giorni lavorativi.*

*Luciano Riposati
Proprietario della villa*



La RE.LE.VI. spa
per i Gazoldesi
1986 - 2006
30 giugno 2006

RE.LE.VI. spa





PISCINA COMUNALE

GAZOLDO DEGLI IPPOLITI - MANTOVA

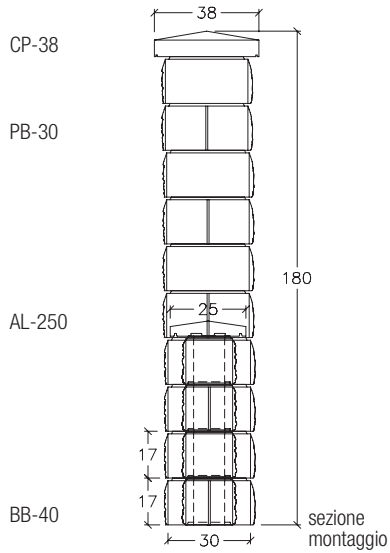





CASA CORRADI

GAZOLDO DEGLI IPPOLITI - MANTOVA

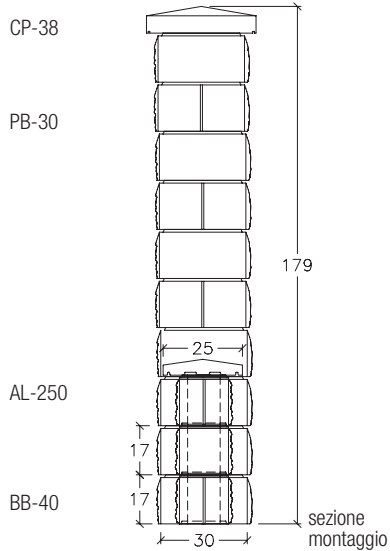

*Era da tempo che cercavo una recinzione bella dentro e fuori.
Finalmente con SAS l'ho trovata. Ha sempre un bell'aspetto ed è
facile da pulire. Sono molto soddisfatta di questa scelta, anche perchè,
con una spesa ragionevole, ho cambiato l'immagine della mia casa.*

*Marisa Corradi
Proprietaria della casa*





Vausshof



HOTEL TAUSHOF

SCENA - BOLZANO

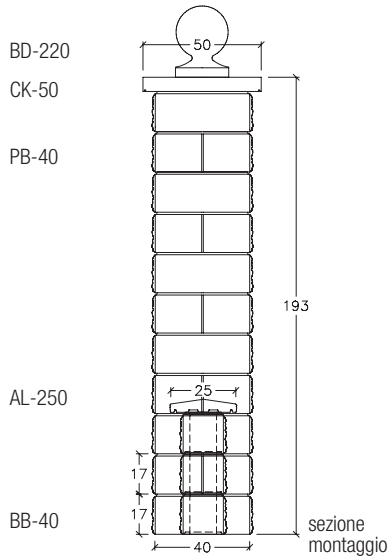

SOLEIL





HOTEL LE SOLEIL

JESOLO - VENEZIA



Pilastrì faccia vista PIL-30, PIL-22
Copripilastrì piani CK-38, CK-28
Copertina a doppia pendenza AL-300





VILLA MAIA ALTA

MERANO - BOLZANO



Pilastro bugnato PB-40
Copripilastro a punta di diamante CP-50
Blocco bugnato BB-40
Copertina bugnata piana CLLO-270





HOTEL SONNENBURG

MERANO - BOLZANO



Piastra bugnata PLB-400





VILLA BROTTO

NOVENTA VICENTINA



Piastra bugnata PLB-400
Copertina bugnata piana CLLO-370





COPERTINE PER MURI GRATICCIATE E COLONNE

PAGINA 102-121



L'amore per i dettagli e lo studio intelligente dei particolari è la formula vincente di SAS. Nulla è lasciato al caso. Anche le Copertine per muri, ovvero le finiture protettive di muri e recinzioni, vengono prodotte in diverse sezioni, larghezze, materiali e colori e rappresentano una sorta di linea perfetta dell'eleganza.

Le Graticciate, in sei architetture diverse, sono

concepite non solo come elemento protettivo, ma per stupire e dare nuovo ritmo alle atmosfere di tutti i giorni.

Ma, a coniugare il gusto classico all'estro creativo della decorazione, sono le Colonne modulari ad incastro. Dall'utilizzo polifunzionale, sono in grado di creare armonia conferendo identità e qualità a ogni genere d'ambiente.

GRATICCIATE





VILLA FIORITA

CAIRO MONTENOTTE - SAVONA

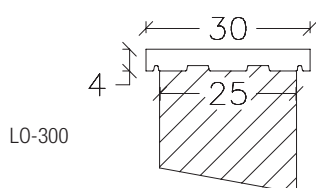

sezione
montaggio

Questa Villa storica dell'entroterra savonese è stata oggetto di una radicale e completa ristrutturazione. La proprietà ha voluto riproporre l'antico splendore della dimora adottando le più evolute tecnologie presenti sul mercato. Le copertine per muro LO-300 sono risultate essere la soluzione più idonea per guarnire i muri perimetrali.

*Geometra Ferrando
Impresa Costruzioni Ferrando*







VILLA FIORITA

CAIRO MONTENOTTE - SAVONA



La scelta di utilizzare materiali SAS nasce dall'esigenza di rivisitare in chiave moderna l'edificio, lasciando inalterate le peculiarità della tradizione locale.

La gamma SAS, per la modularità dei prodotti e la perfetta resistenza al gelo, trova applicazione in vari contesti. In questo caso, per dividere la terrazza antistante il giardino, abbiamo scelto le graticciate mod. C-255B.

*Geometra Ferrando
Impresa Costruzioni Ferrando*







RESIDENZE MALASPINA PIRELLI RE AGENCY

PIOLTELLO - MILANO

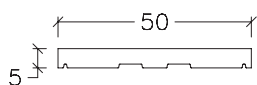

LO-500

Si cercava un prodotto bello e resistente, soprattutto compatibile con la linea di design del progetto. Le copertine per muri tipo LO-500 bianche sono risultate essere la soluzione ideale per pavimentare la piazza del villaggio Malaspina all'interno del nuovo impianto urbanistico nei dintorni di Milano.

*Michele Larcher
Importatore SAS*

sezione
montaggio







RESIDENZE MALASPINA PIRELLI RE AGENCY

PIOLTELLO - MILANO

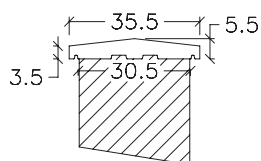

AL-355

sezione
montaggio







CAMPING SIRMIONE

SIRMIONE - BRESCIA

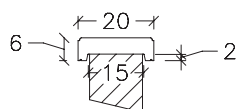

CU-200

sezione
montaggio



Copertina CU-200





VILLA ZUNINO

SANREMO

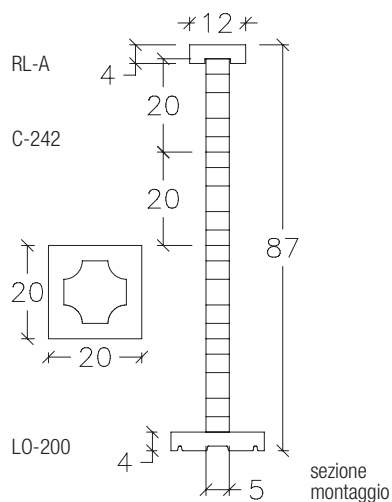

Ubicata nelle vicinanze del casinò di San Remo, la villa fa parte del contesto storico urbano legato alle proprietà del Senatore del Regno d'Italia Ernesto Marsaglia. L'edificio si distingue per la linea moderna e la ricerca di materiali non legati al territorio. Con l'utilizzo dei prodotti SAS, la proprietà ha voluto donare alla villa un ulteriore tocco di distinzione e ricercatezza.

*Michele Larcher
Importatore SAS*







HOTEL QUELLENHOF

VAL PASSIRIA - BOLZANO

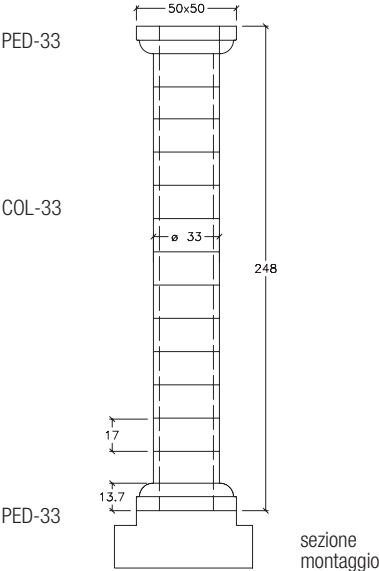

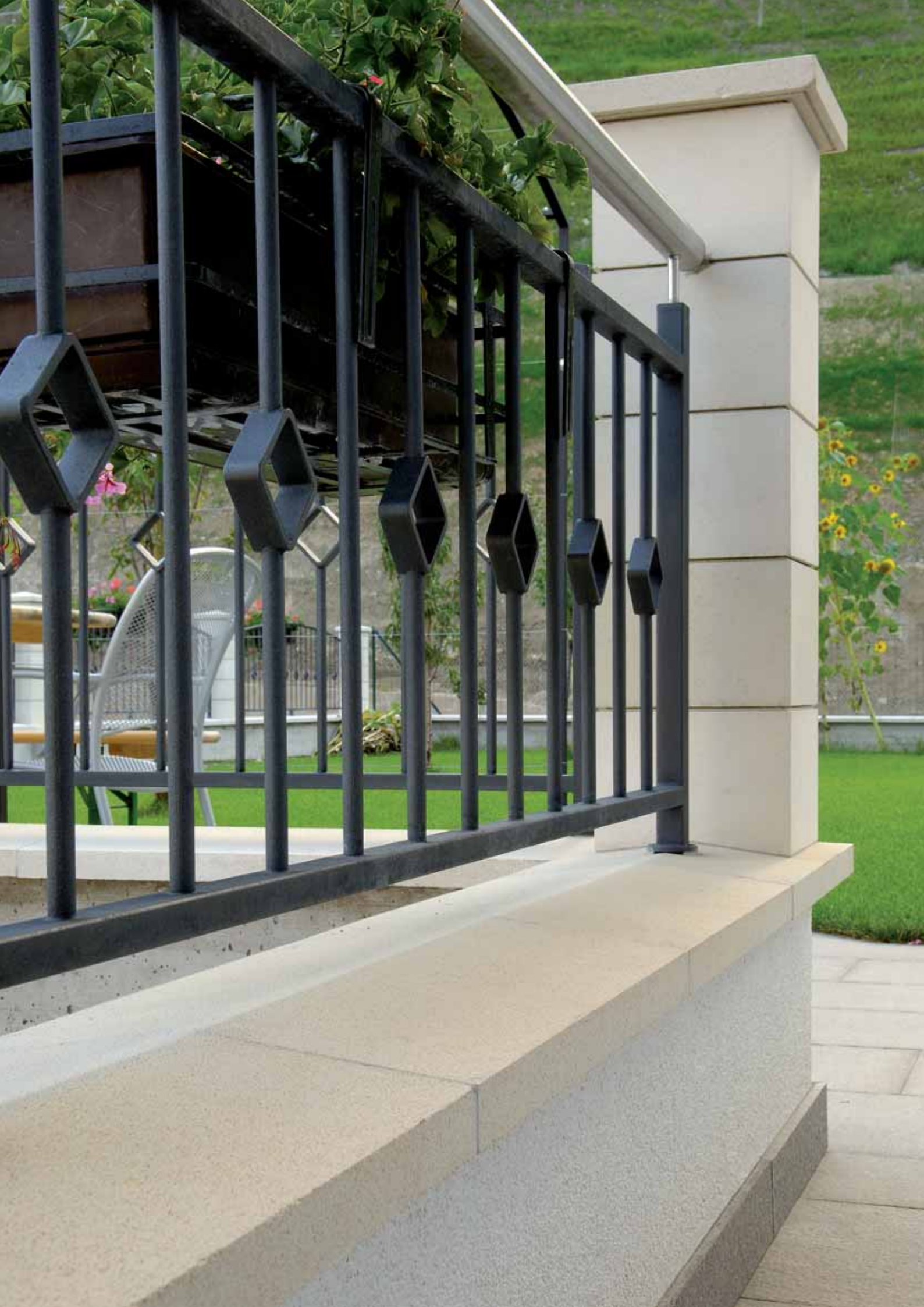



CASA GIULIANI JOSEF

APPIANO RIVA DI SOTTO - BOLZANO



Pilastro faccia vista PIL-22
Copripilastro a punta di diamante CP-28
Copertina a doppia pendenza AL-300
Copertina piana LO-300





MONASTERO DEI FRATELLI CONTEMPLATIVI DI GESÙ

CAPRIATA D'ORBA - ALESSANDRIA

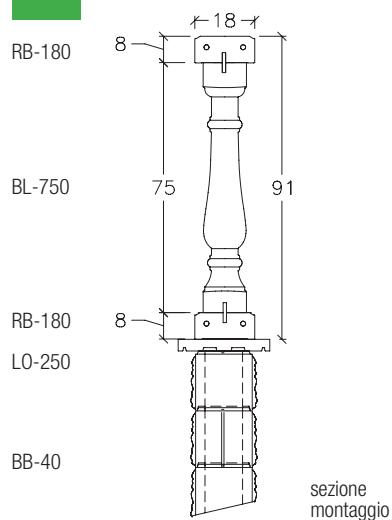

*L'utilizzo dei prodotti SAS è particolarmente indicato
nelle costruzioni in stile Liberty.*

*Paolo Crocco
Artigiano posatore*







PIETRE RICOSTRUITE

PAGINA 122-125



Anticamente i muri in pietra a vista erano l'unica soluzione possibile, ora sono un prodotto ornamentale di gran pregio. La tecnologia SAS è capace di riprodurre, in breve tempo, quello che la natura forgia in milioni d'anni. Con soli tre centimetri di spessore rivestimento è possibile creare, su qualsiasi superficie, l'effetto rustico di una vecchia costruzione. Impasti

di calcestruzzo di diverse tonalità cromatiche, ottenute mediante l'impiego di ossidi di ferro, vengono accostati in modo casuale e il risultato sulle pietre è simile alle caratteristiche venature prodotte dalla natura. La pietra ricostruita SAS è resistente agli agenti atmosferici e stabile ai raggi solari. La scelta ideale per chi ama il piacere semplice della tradizione.

PIETRE



Pedra de Poblet



RIVESTIMENTO POBLET



Il Monastero di Santa Maria di Poblet, in Catalogna è uno dei più importanti complessi monastici d'Europa. In esso si trovano le tombe di otto sovrani della corona di Catalogna e d'Aragona. Nel 1991 il luogo è stato dichiarato patrimonio dell'umanità dall'UNESCO.

Vari sono gli stili che si sono aggiunti al nucleo originario del complesso cistercense, dal romanico al gotico, al rinascimentale fino al barocco, sempre con

uso di "Pedra de Poblet". Proprio per la somiglianza con questa famosa pietra abbiamo denominato Poblet i nostri rivestimenti. Il Rivestimento Poblet è disponibile nei formati da cm 20x20, 20x40, 20x30, 30x30, 30x60 e nelle colorazioni in pasta: Caliza (Bianco sporco), Albero (Beige-Giallo) e Pireneos (Grigio).

Un'arte capace di reinterpretare le magiche atmosfere del passato.

RIVESTIMENTO MANSUS



Mansus è una parola latina che significa "abitazione agricola circondata da terreno coltivato". La parola "maso" è ancor oggi utilizzata nei territori dolomitici per indicare l'abitazione e il podere agricolo sul quale lavora un'unica famiglia.

Il Rivestimento Mansus è stato così denominato in quanto ricorda la struttura in sasso spaccato delle vecchie case contadine.

Il rivestimento Mansus è disponibile in

scatole di cartone contenenti 66 diverse forme di pietra, inserite casualmente, dalle colorazioni in pasta: Caliza (Bianco sporco), Albero (Beige-Giallo) e Pireneos (Grigio).

Questo prodotto, se inserito in nuove architetture, le riqualifica con una sensibilità d'altri tempi e riporta qualità e armonia nel rapporto tra l'uomo e l'ambiente moderno.







Sede, Uffici tecnici, Consulenza e
Realizzazione progetti

Aldo Larcher
Importatore esclusivo SAS per l'Italia
I-39057 Appiano (BZ)
Via Artigiani 5
tel. +39 0471 662486
fax +39 0471 661790
sas@aldolarcher.com
www.sas-sa.it

Questo catalogo è stato realizzato grazie
alla collaborazione dei nostri clienti.
È attraverso informazioni personali e per
merito della vostra creatività che spesso
scopriamo nuove possibilità di utilizzo dei
prodotti SAS. Se desiderate che il vostro
cantiere venga inserito nella prossima
pubblicazione, potete inviare una foto con
il vostro nome e indirizzo a:
sas@aldolarcher.com



„Spanish Caravan“ (The Doors)